



User's Manual

ZNR Series

ZNR-126, ZNR-127, ZNR-423, ZNR-424

2023/05/22



ACTi
Connecting Vision

Table of Contents

Table of Contents	1
Preface	5
Safety Information.....	5
Regulatory Compliance	6
LVD/EMC Directive.....	6
WEEE Directive–2012/19/EU	6
Battery Directive-2013/56/EC	6
Part I Local Operations	7
Before You Begin	7
Disk Installation.....	7
Ports and LEDs.....	12
Login.....	14
Local Operations.....	14
Initial Configuration	17
Preparation	17
Device Login.....	17
Wizard	19
Live View	21
Live View Status	21
Window Toolbar.....	21
Screen Toolbar	22
Shortcut Menu	22
Sequence Operation.....	24
Zoom	25
Image Configuration	25
Preview Configuration.....	26
Channel Configuration	28
Channel Management	28
OSD Configuration.....	35
Image Configuration	36
Privacy Mask Configuration	40

PTZ Control.....	41
PTZ Control Window and PTZ Management Window	41
Setting and Calling a Preset	42
Setting a Preset Patrol.....	43
Setting a Recorded Patrol.....	44
Setting Auto Guard	44
Recording and Snapshot.....	45
Encoding Settings.....	45
Draw or Edit a Schedule	47
Scheduled Recording and Snapshot	48
Motion Detection Recording and Snapshot	49
Alarm Triggered Recording and Snapshot.....	51
Manual Recording and Snapshot.....	53
Holiday Recording and Snapshot	54
Other Recording and Snapshot Types.....	55
Playback.....	56
Instant Playback	56
Playback Toolbar	56
Playback by Camera and Date	57
Playback in Corridor Mode	59
Playback by Tag	59
Playback by Motion Detection	60
Playback by Video Loss.....	60
Playback by Smart Search	60
Playback by External File	61
Playback by Image	61
File Management.....	62
Backup	63
Recording Backup	63
Image Backup.....	64
Alarm	65
Alarm Input and Output.....	65
Motion Detection.....	67
Tampering Detection	68
Human Body Detection.....	68
Video Loss.....	69
Alert	70

Audio Detection	71
Buzzer	71
Doorbell Call	72
Alarm-Triggered Actions	72
Manual Alarm	72
VCA.....	74
VCA Configuration	74
VCA Search.....	87
Network Configuration	88
Basic Configuration.....	88
Platform Configuration	91
Advanced Configuration	95
Disk Configuration	100
Disk Management.....	100
Space Allocation	101
Advanced Configuration	102
System Configuration.....	103
Basic Configuration.....	103
Time Configuration	103
User Configuration.....	105
Security Configuration	106
System Maintenance.....	108
System Information.....	108
Network Information.....	110
Log Query.....	111
Import/Export	112
System Restoration	112
Automatic Maintenance	113
System Upgrade	113
Hard Disk Detection.....	114
Shutdown	115
Part II Web-Based Operations.....	116
Before You Begin.....	116
Login.....	117

Live View118
Playback.....120
Configuration121

Appendix A Typical Applications 122
 Typical Application 1122
 Typical Application 2.....122

Appendix B Acronyms..... 123

Appendix C FAQs..... 124

Preface

This manual describes how to use your NVR locally or on the Web interface.

In this manual, the terms IP camera and IPC refer to the same thing: network camera, which requires a connection to the network. And the IP device mentioned in this manual refers to an IP camera (also known as network camera) or a Digital Video Server (DVS).

Thank you for purchasing our product. Contact your local dealer if you have any questions or feedback. No part of this manual may be copied, reproduced, translated, or distributed in any form or by any means without prior consent in writing from our company. Contents of this manual are subject to change without prior notice. No statement, information, or recommendation in this manual shall constitute formal guarantee of any kind, expressed or implied.

Safety Information

Read through the instructions carefully before starting installation and operation.

Installation and maintenance must be performed by qualified personnel.

This device is a class A product and may cause radio interference. Take measures if necessary.

Disconnect power before installation and cable connection. Wear antistatic gloves during installation. Use the manufacturer recommended battery. Improper use or replacement of the battery may cause risk of explosion. Dispose of the used battery according to local regulations or the battery manufacturer's instructions. Never dispose of the battery in fire.

The device is intended for indoor use only. Ensure a proper operating environment, including temperature, humidity, ventilation, power supply, and lightning protection. The device must always be properly grounded. Keep the device from dust, excessive vibration, liquid of any kind, and strong electromagnetic radiation. A sudden power failure may cause device damage or loss of data.

Take necessary measures to ensure data security and protect from network attack and hacking (when connected to Internet).

Regulatory Compliance

FCC Part 15

This equipment has been tested and found to comply with the limits for digital device, pursuant to part 15 of the FCC Rules. These limits are designed to provide reasonable protection against harmful interference when the equipment is operated in a commercial environment. This equipment generates, uses, and can radiate radio frequency energy and, if not installed and used in accordance with the instruction manual, may cause harmful interference to radio communications. Operation of this equipment in a residential area is likely to cause harmful interference in which case the user will be required to correct the interference at his own expense.

This product complies with Part 15 of the FCC Rules. Operation is subject to the following two conditions:

- This device may not cause harmful interference.
- This device must accept any interference received, including interference that may cause undesired operation.

LVD/EMC Directive

 This product complies with the European Low Voltage Directive 2014/35/EU and EMC Directive 2014/30/EU.

WEEE Directive–2012/19/EU



The product this manual refers to is covered by the Waste Electrical & Electronic Equipment (WEEE) Directive and must be disposed of in a responsible manner.

Battery Directive-2013/56/EC



Battery in the product complies with the European Battery Directive 2013/56/EC. For proper recycling, return the battery to your supplier or to a designated collection point.

Part I Local Operations

An NVR supports two types of operations: local operations and web-based remote operations. With local operations you connect a monitor and a mouse to the NVR and use the mouse to operate. If your NVR has buttons on the front panel or is delivered with a remote control, you may also control your NVR by pressing the front panel buttons or using the remote control.

The NVR has an embedded web server and allows web-based operations. To do this, you need a PC that has a network connection to the NVR and is installed with a web browser. You just need to navigate to the NVR's IP address and log in to the Web interface like you log in to the system locally.

This section describes local operations.

Before You Begin

Please be aware that the parameters that are grayed out on the system user interface (UI) cannot be modified. The parameters and values displayed may vary with device model, and the figures in this manual are for illustration purpose only.

Disk Installation

CAUTION: Disconnect the power before installation. Use an antistatic gloves or wristband throughout the installation.

ZNR-126 / ZNR-127

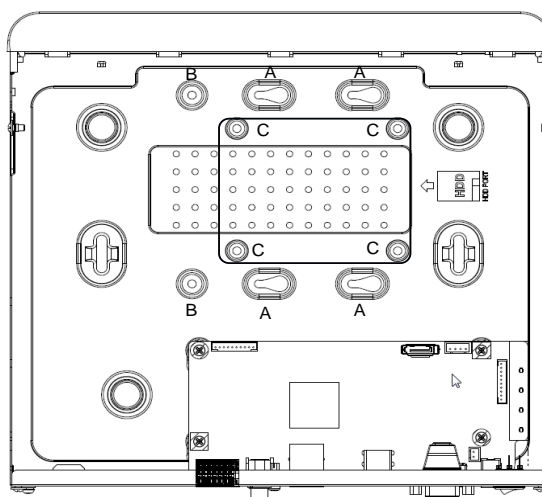

The screw holes are for different uses:

- **A:** For 3.5" HDD with 4 screw holes.
- **A and B:** For 3.5" HDD with 6 screw holes.
- **C:** For 2.5" HDD.

ZNR-423 / ZNR-424

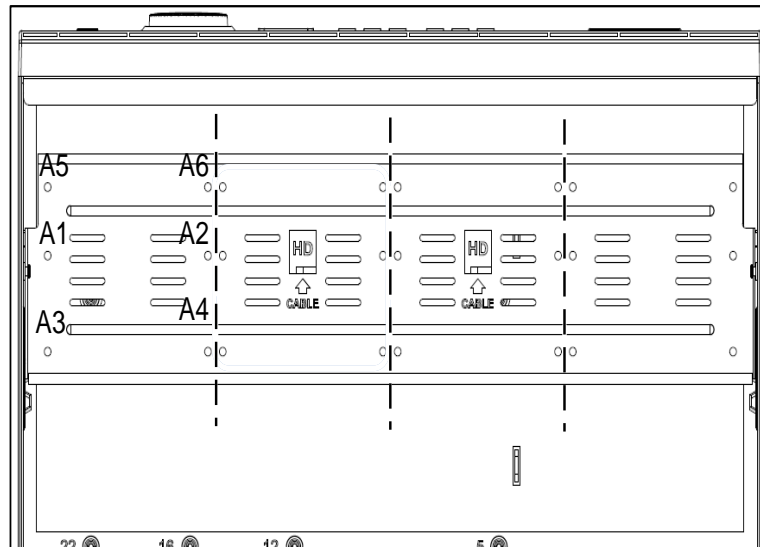

The screw holes are for different uses:

- **A:** For 3.5" HDD with 4 screw holes.
- **A and B:** For 3.5" HDD with 6 screw holes.

NOTE:

- The three (3) dotted lines (for illustration only) divide the four sets of screw holes. Do not install across the lines.
- An 8 HDD device has two (2) mounting plates. Take out the mounting plates, secure all disks on the mounting plates, and then fix the mounting plates in the device.

The dotted lines indicate the cable connection side (may vary with device). Make sure the disk faces the correct side for installation.

Choose an option as appropriate. Use a #1 or #2 screwdriver as needed. All photos are for illustration purposes only.

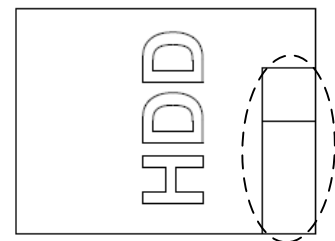

One or Two Hard Disk Installation

1. Loosen the screws on the rear and side panels. Remove the cover.

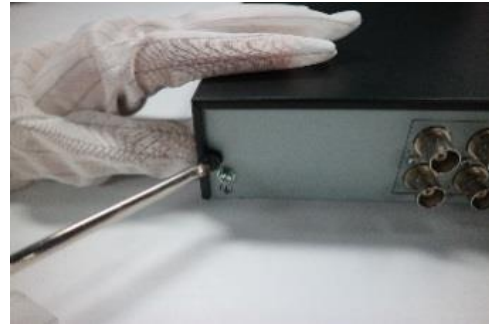

2. Connect the data and power cables to the disk.



3. Loosen the screws on the disk halfway.



4. Slide the disk in the screw holes, and then tighten the screws.

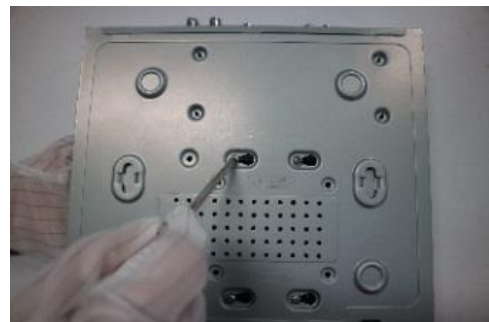

5. Connect the power cable and the data cable to the motherboard.



6. Put the cover back in place and tighten the screws.

Four or Eight Hard Disk Installation

1. Loosen the screws on the rear panel. Then press with both thumbs and slide open the cover.



2. Loosen the screws on both sides and take out the mounting plate.



3. Secure the disks on the mounting plate and tighten the screws.



4. Place the mounting plate back in place.

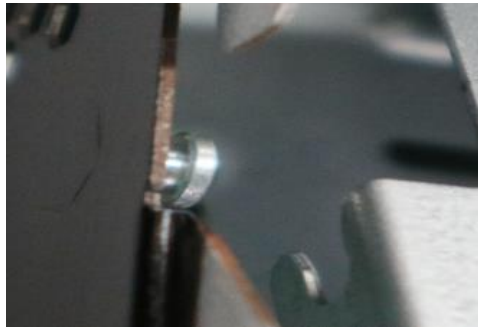

5. Tighten screws on both sides to secure the mounting plate.



6. Connect the power and data cables to the disk. Connect the cable to the mother board.

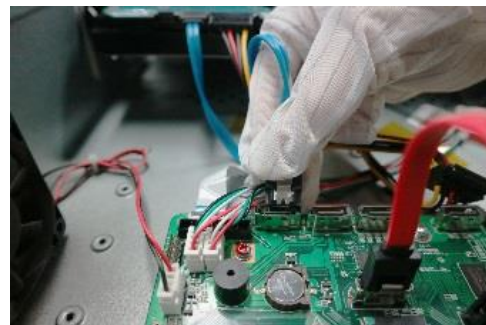

7. Put the cover back in place and tighten the screws on the rear panel.



Ports and LEDs

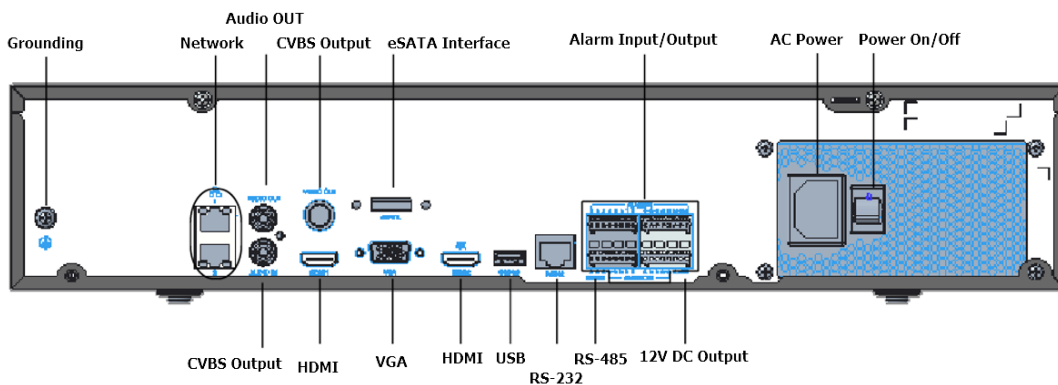
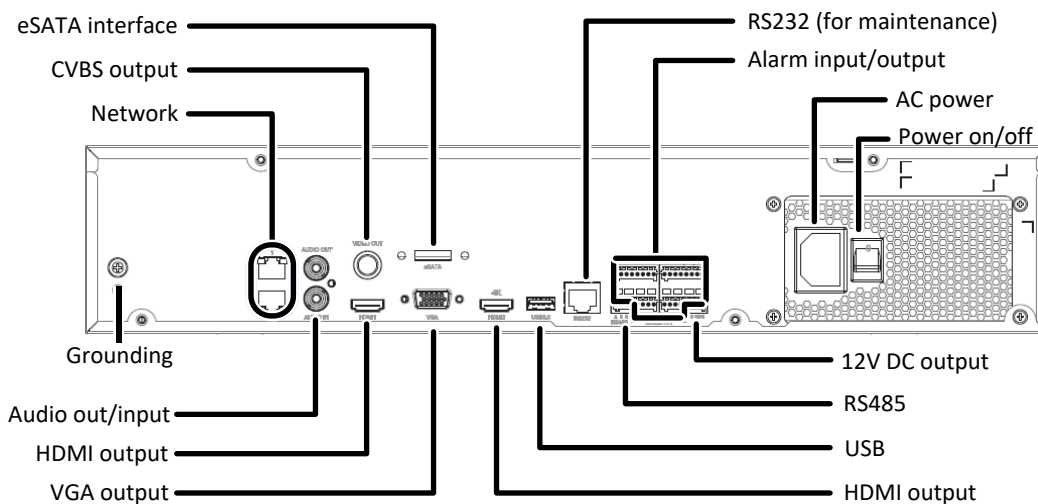
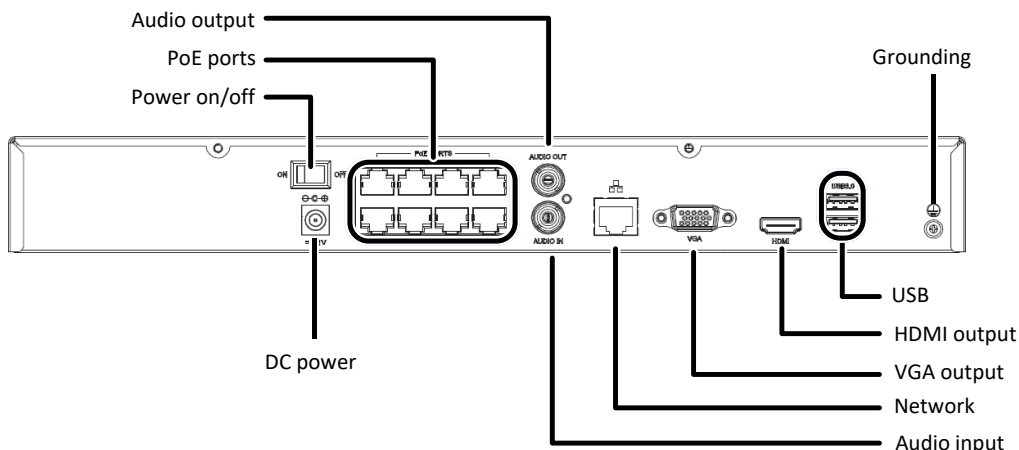

Name	Description
PWR(Power)	Steady on: Connected to power.
RUN(Operation)	• Steady on: Normal.

Name	Description
	<ul style="list-style-type: none"> Blinks: Starting up.
NET(Network)	Steady on: Connected to network.
GUARD (Arming)	Steady on: Arming is enabled.
IR	<ul style="list-style-type: none"> Steady on: Activated for remote control. Blinks: Authenticating device code.
ALM (Alarm)	Steady on: Device alarm occurred.
CLOUD	Steady on: Connected to cloud.
HD(Hard disk)	One HD LED only: <ul style="list-style-type: none"> Steady on: No disk; or disk is abnormal. Blinks: Reading or writing data. One HD LED for each disk: <ul style="list-style-type: none"> Steady green: Normal. Blinks green: Reading or writing data. Steady red: Abnormal. Blinks red: Rebuilding array.

Login

Use the default username **admin** and password **123456** for your first login.



CAUTION: The default password is intended only for the first login and should be changed to a strong one containing at least eight characters including uppercase and lowercase letters, digits and symbols after your first login to ensure security.

1. Right-click anywhere in the window and then choose **Menu**. The login dialog box is displayed.
2. Select the username from the drop-down list, enter your password, and then click **Login**.

Local Operations

You can refer to *Initial Configuration* and complete a quick configuration.

NOTE: Unless otherwise specified, all operations described in this manual are performed with a mouse by the right hand. See **Mouse Operations** below for details.







Mouse Operations

Name	Action	Description
Left button	Click	Select or confirm an item. Select to edit digits, symbols, upper-case or lower-case letters in a field.
	Double-click	Enter or exit full screen mode in live view.
	Drag	Draw or move a rectangle on the screen, for example, a motion detection area.
Right button	Click	Show the shortcut menu. Exit zoom. Exit the current window when Cancel or Exit is displayed.
Wheel	Scroll up or down	Scroll up or down a list or a window; or zoom in or out on a playback progress bar.
	Long press	Restore to lowest resolution.





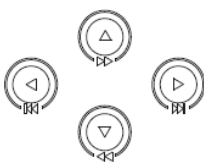

Front Panel Buttons











The front panel buttons and its availability may vary with NVR model.

Front Panel Buttons 1

Button	Description
	Display the main menu.
	Switch to the next tab on the screen or switch the input method.
	Auxiliary function button.
	Exit the current window.
	<ul style="list-style-type: none"> △, ▽, ▷, ◁: Switch windows or menu items; or control rotation directions of a PTZ camera when the PTZ toolbar is closed. PTZ stands for pan, tilt, and zoom. ⏮, ⏭: Rewind or forward 30 seconds in full screen. ⏩, ⏪: Variable-speed forward or rewind in full screen.
	Confirm an operation, or start/pause the playback.
	<p>Press this button to start up or shut down the NVR. To shut down, press this button and hold for at least 3 seconds till a message appears on your monitor. Click Yes.</p> <p>NOTE: This shutdown operation can be performed only when you have logged in to the system.</p>

Front Panel Buttons 2

Button	Description
	<p>Press this button to start up or shut down the NVR. To shut down, press this button and hold for at least 3 seconds till a message appears on your monitor. Click Yes.</p> <p>NOTE: This shutdown operation can be performed only when you have logged in to the system.</p>
	Enter 1; or display the main menu.
	Enter 2, A, B, or C; or start instant playback.
	Enter 3, D, E, or F; or start manual recording.
	Enter 4, G, H, or I; or enter the PTZ control interface.
	Enter 5, J, K, or L; or switch the screen layout in live view or playback mode.

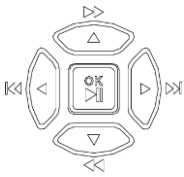
Button	Description
	Enter 6, M, N, or O; or enable or disable arming.
	Enter 7, P, Q, R, or S; or take a snapshot.
	Enter 8, T, U, or V.
	Enter 9, W, X, Y, or Z.
	Enter 0 or a space.
	Delete
	Switch the input method.
	Auxiliary function button.
	Exit the current window.
	Switch to the next tab.
	<p>△, ▽, ▷, ◁: Switch windows or menu items; or control rotation directions of a PTZ camera when the PTZ toolbar is closed</p> <p>⏮, ⏭: Rewind or forward 30 seconds in full screen.</p> <p>⏩, ⏪: Variable-speed forward or rewind in full screen.</p> <p>OK ▶⏮ : Confirm an operation; or start or pause playback.</p>

Initial Configuration

Preparation

Make sure that at least one monitor is correctly connected to the VGA or HDMI interface on the rear panel of the NVR.

Verify that the hard disk(s) are correctly installed. For detailed steps to install a hard disk, please refer to the quick guide shipped with your NVR.

Device Login

The login page appears after the NVR starts up.

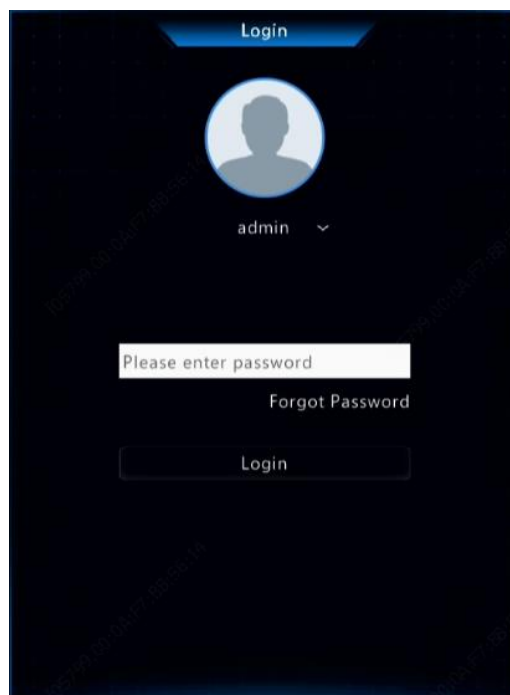

1. Enter the default admin password **123456**, click Login, and then click **Yes** to change the password.

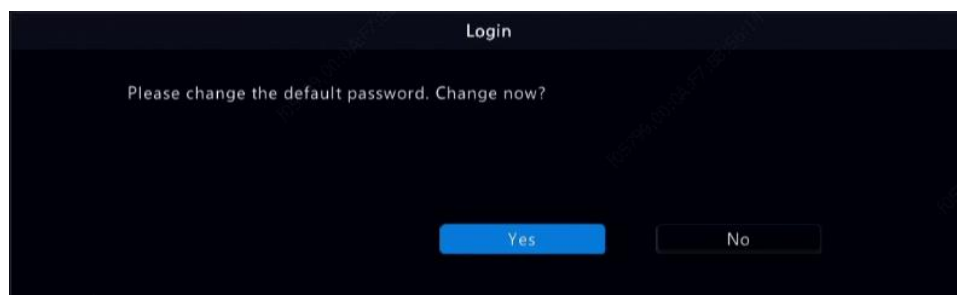

2. Change the password into a strong one, then click **OK**.

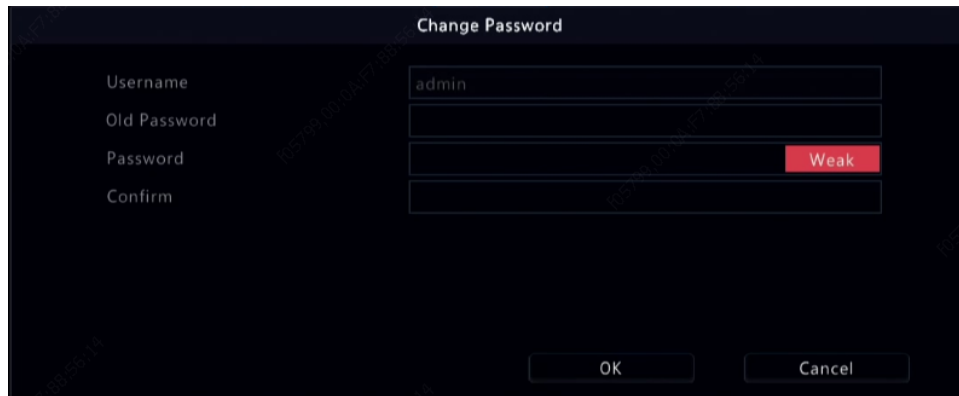

Change Password

Username: admin

Old Password:

Password: Weak

Confirm:

OK Cancel

3. Set the unlock pattern.

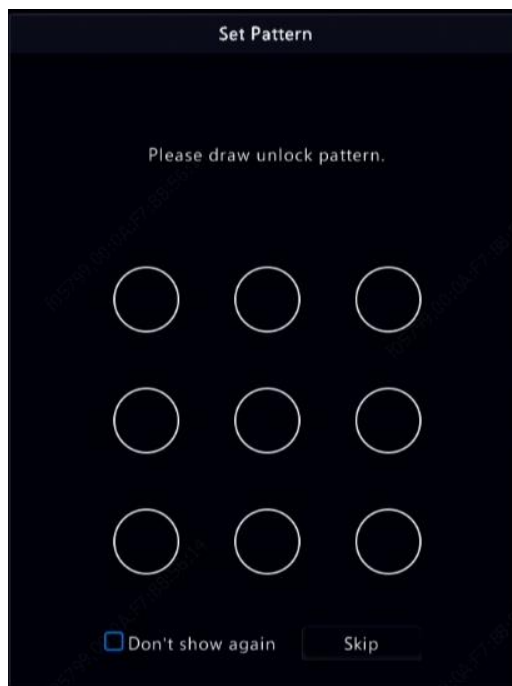

Set Pattern

Please draw unlock pattern.

Don't show again Skip

NOTE: To disable the unlock pattern, click **System > User**. See [User Configuration](#) for details.

Wizard

The wizard can guide you to complete the most basic setup. The wizard may vary with device model and other factors. The following shows an example.

1. Enable or disable the wizard as needed and then click **Next**. You may also click **2** (Number 2).



2. Select the time zone, date and time format, set the system time, and then click **Next**.



3. Complete the network configuration, and then click **Next**.



4. Select the devices to add in the discovered device list, click **Add**, and then click **Yes** to complete the configuration.



NOTE:





- The devices added can get online and start live only if the device password is default. If not, you need to modify the device password.
- If the desired device is not in the device list, you may add it in a preview window or under **Camera > Camera > Camera** (see [Adding an IP Device](#)).

Live View















Live View Status

The following icons are used to indicate alarms, recording status, and audio status in a live view window.













Live View Window Icons

Icon	Description
	Tampering alarm
	Motion detection alarm
	Recording
	Two-way audio

Window Toolbar

Icon	Description
	Available for PTZ cameras only. Click to display the PTZ control window.
	Set mount mode and display mode for fisheye camera. This icon appears only for fisheye cameras.
	Record live video in the window to the hard disk. Clicking  stops recording.
	Click to play video recorded during the past 5 minutes and 30 seconds.
	Zoom in on an area of interest.
	Click to edit image settings.
	Click to set OSD.
	Click to take a snapshot. The window borders will flash white. You may view and back up snapshots under Backup > Image .
	Rest your mouse pointer on the icon to view live video information. Or click it to view the channel number, camera name, IP address, connection status and recording status.
	Start two-way audio with the camera. Click  to stop. The sound volume is adjustable. NOTE: Correct audio input and output connections are required.
	Click to turn on audio. Clicking  turns off audio. The sound volume is adjustable. NOTE: When you turn on audio in the current window, audio of the previous window is turned off.

Screen Toolbar

Icon	Description
	Click to access the main menu.
	Select the screen layout.
	Previous or next screen.
	Start or stop sequence.
	Playback.
	Rest the mouse pointer on this icon to view encoding information including frame rate, bit rate, and resolution; or click to view camera status.
	Click to view device alarm status and camera status.
	Rest the mouse pointer on it to view NIC card information. Or click this icon to edit basic network settings.
	Rest the mouse pointer on it to view the date. Or click this icon to edit time settings.
	Available to certain NVR models. Click to display the cloud service window. You may scan the QR code and download an app to manage your NVR.
	Click to automatically hide the toolbar, or click  to lock.

Shortcut Menu

A shortcut menu as shown below appears when you right-click in a window. Some menu items are described in [Shortcut Menu Description](#).

Shortcut Menu

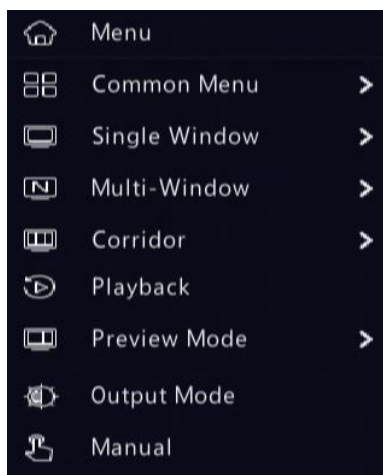

Shortcut Menu Description

Menu	Description
Menu	<p>Access the main menu.</p> <p>Most of operations described in this manual are performed start from the main menu; for example, click Camera > Camera (with Menu > omitted).</p>
Common Menu	Quick access to Camera , Net Config , and Backup .
Corridor	<p>Choose a corridor mode. Corridor mode can also be set in the Preview Windows drop-down list under System > Preview.</p> <p>To display images in corridor mode, the camera must be installed correctly (rotated 90° clockwise or counterclockwise), and then use the Image Rotation parameter under Camera > Image to rotate images accordingly.</p>
VCA Search	Search among the video analytics
Preview Mode	<p>Switch between Normal and Smart.</p> <p>The default is Normal mode.</p>
Playback	Play the current day's recording for the camera linked to the current window.
Output Mode	Choose a video output mode, including standard, soft, bright, and vivid.
Manual	Manual settings include manual recording, manual snapshot, and manual alarm.

Sequence Operation

The sequence operation requires you to configure the screen layout, windows, linked cameras, and the sequence interval.

This example describes how to configure sequence for five cameras based on a 4-window screen layout.

1. Click **4 Windows** on the screen toolbar.

NOTE: The number of windows that can be displayed may vary with NVR model.

2. Click **Start Sequence** on the screen toolbar. Sequence starts by displaying four windows on the first screen and then the fifth on the second screen at the set interval.



NOTE:

- The default sequence interval is eight seconds and can be set under **System > Preview**.
- You may drag video to the desired window on the screen.

Zoom

Zoom in on an area of images in a window for details.

1. Click the window and then click  on the window toolbar.



2. Move your mouse to the area you want to zoom in, then use your scroll wheel to zoom in and out.
3. Right click to exit zoom.

Image Configuration

Adjust image settings to get optimal images from a camera.

1. Click the window and then click  on the window toolbar.
2. Select a mode from the drop-down list according to the surveillance scenario, and then adjust contrast, hue, saturation and brightness as needed. The settings available may vary with device model.
3. Click **OK** to save the settings and exit.

Preview Configuration

Normally, live view (video) is available after you complete the basic setup by following the wizard. You can click **System > Preview** and edit preview setting as needed, including video output, image resolution, default layout, and sequence interval. The video output and the number of windows supported may vary with NVR model.

NOTE: Pressing and holding the scroll wheel for at least 3 seconds will restore the default resolution.

Preview Configuration

Each preview window (window for short) links to a camera. By default, window 1 links to camera D1, window 2 links to camera D2, and so on. You may want to change the link to display live video from a camera in another specified window. The following example describes how to link window 1 to camera D2 and link window 2 to camera D1.

1. Click window 1 on the right, and then click **D2** under **Camera** on the left. Now **D2** appears in window 1, and **None** appears in window 2. Meanwhile, is cleared for camera D1, meaning D1 is not linked to any window.



2. Click window 2 on the right, and then click **D1** under **Camera** on the left. Now **D1** appears in window 2. Click **Apply** to save the settings.

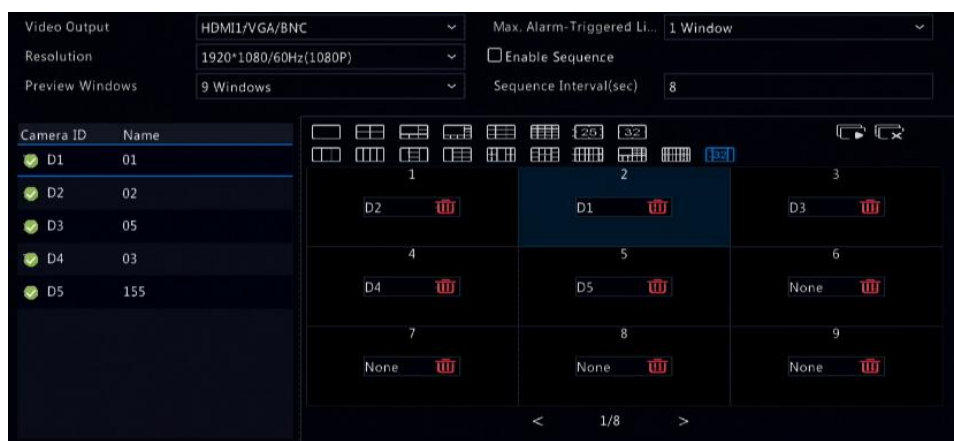

Advanced Configuration

Click the **Advanced** tab and then select **Sub Stream First** so the NVR uses the sub stream to establish live video from multiple cameras simultaneously. This function is disabled by default.

Channel Configuration

Channel Management

This chapter describes how to add and manage IP devices in your NVR. The IP devices mentioned in this manual mainly refer to IP camera (or network camera); sometimes they can also be Digital Video Server (DVS). Before you start, make sure the IP devices are connected to your NVR via network.



CAUTION: An IP device should be connected to one NVR only. An IP device managed by multiple NVRs may cause unwanted issues.

Adding an IP Device

This section provides multiple options to add an IP device. Some options are only applicable to certain NVR models. Choose one as appropriate.

Option 1

1. Click **Camera > Camera > Camera**. The system automatically searches for IP devices and lists the discovered.

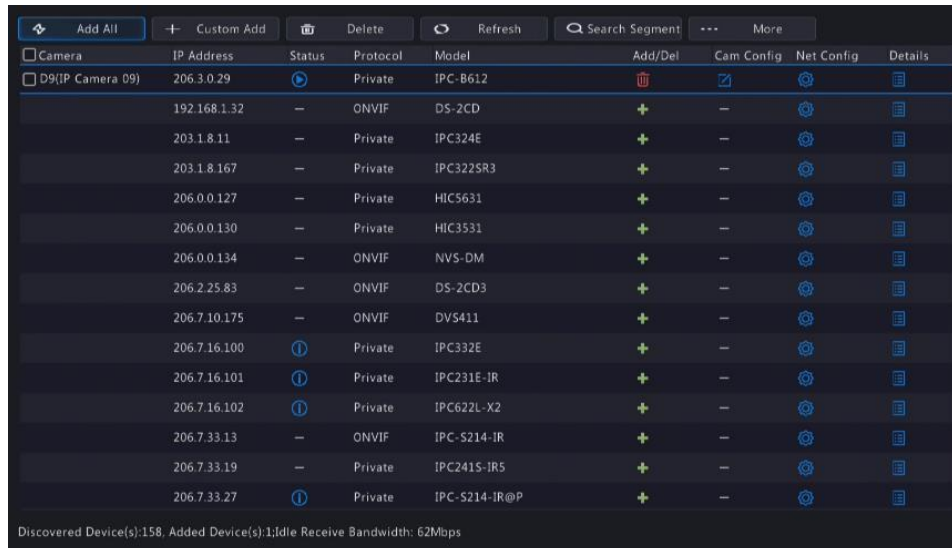

Camera	IP Address	Status	Protocol	Model	Add/Del	Cam Config	Net Config	Details
<input checked="" type="checkbox"/> D9(IP Camera 09)	206.3.0.29		Private	IPC-B612				
	192.168.1.32	—	ONVIF	DS-2CD	+	—		
	203.1.8.11	—	Private	IPC324E	+	—		
	203.1.8.167	—	Private	IPC3225R3	+	—		
	206.0.0.127	—	Private	HIC5631	+	—		
	206.0.0.130	—	Private	HIC3531	+	—		
	206.0.0.134	—	ONVIF	NVS-DM	+	—		
	206.2.25.83	—	ONVIF	DS-2CD3	+	—		
	206.7.10.175	—	ONVIF	DVS411	+	—		
	206.7.16.100		Private	IPC332E	+	—		
	206.7.16.101		Private	IPC231E-IR	+	—		
	206.7.16.102		Private	IPC622L-X2	+	—		
	206.7.33.13	—	ONVIF	IPC-S214-IR	+	—		
	206.7.33.19	—	Private	IPC241S-IR5	+	—		
	206.7.33.27		Private	IPC-S214-IR@P	+	—		

Discovered Device(s):158. Added Device(s):1,Idle Receive Bandwidth: 62Mbps

2. (Optional) To search a specified network segment, click **Search** and then set the address range.
3. You may choose one of the following ways to add an IP device:
 - a. Click **Add All** to add all the discovered IP devices allowed (depending on channels supported by the NVR).

- b. Click **Custom Add**. In the window displayed, enter the IP address and complete other settings, and then click **Add**. You may also click **Search Segment** and add discovered cameras in the list.
- c. Click **+** to add the camera.

NOTE: For a Digital Video Server (DVS), a window appears when you click **Add**, and you need to select channels to add the connected cameras.

Option 2

This option is not applicable to NVRs with PoE ports or switching ports.

1. Click **+** in a window.
2. Select the desired IP device and then click **Add**.

Option 3

Use this option to add an IP device that is connected to a different router, for example, when the NVR and the IP device are connected across the Internet.

NOTE: First you need to enable port mapping at **Setup > Port > Port Mapping** on the IP device web interface.

1. Click **Camera > Camera**, click **Custom Add**.
2. Choose an option:
 - By IP
 - a. On the IP device web interface, go to **Setup > Port > Port Mapping**, find the external IP (public IP) and external port number.
 - b. On the NVR, select a protocol, enter the above-mentioned IP address and port number, enter the username and password.
 - c. Click **OK**.
 - By MyDDNS
 - a. On the IP device web interface, go to **Setup > Network > DDNS**, enable DDNS, select **MyDDNS**, set a domain name and get the server address.





NOTE:

- After setting the domain name, check that you can use the device address to access the IP device web interface.
- Make sure the MyDDNS server and the NVR are connected (ping the MyDDNS server from the NVR).

- b. On the NVR, select a protocol. Enter the above-mentioned server address, domain name, username and password.
 - c. Click **OK**.
- By Domain Name
 - a. On the IP device web interface, go to **Setup > Network > DDNS**, enable DDNS, select **DynDNS** or **NO-IP**, enter the domain name that you have signed up on the DNS website, enter the username and password, and then click **Save**.
 - b. On the NVR, select a protocol, enter the domain name mentioned above, enter the username and password. The port is the external port of the IP device.
 - c. Click **OK**.

Managing an IP Device

Manage IP devices under **Camera > Camera > Camera**.

1. Click  to edit settings including the protocol, IP address, port number, username and password. The **Camera IP** field displays the IP address that the current channel links to, and you may change the address so the channel links to another device. The username and password must be consistent with that of the IP camera.
2. Click  to delete an IP device, or select multiple IP devices and then click **Delete**. Channels corresponding to PoE ports or switching ports cannot be deleted.
3. Click  to change the IP address of an IP camera and the default gateway. A DVS' IP address cannot be edited from the NVR.  means this function is not available.

Sort Cameras

Sort cameras to display in the desired order.

NOTE:

- This function is not available on NVR's with PoE ports or switching ports.
- This chapter describes how to sort cameras on an NVR with more than 32 channels. For NVRs with 32 channels or less, you can sort cameras by dragging the mouse.

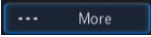
For example, to switch channel 1 with channel 4, click , and choose **Sort Camera**, and then follow the steps below:

1. From the preview window, drag the channel from one window to another.

2. Click right to exit Sort Camera mode.
3. On the pop-up window, click **Yes** to apply and save the setting.

Batch Edit Password

If the password you used to add the cameras is incorrect, use this function to batch edit the password used for authentication.

NOTE: The cameras can be added to NVR successfully only when authentication password is correct.

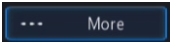
1. Select the cameras with the same password.
2. Click , and then select **Batch Edit Password**.
3. Enter the correct camera password.
4. Click **Confirm**, then check whether password is changed successfully in **Status** window.

NOTE: The cameras can be added to NVR successfully only when authentication password is correct.

5. Click **OK**.

Fisheye Configuration

Only certain NVR models support this function. Parameters must be set correctly in accordance with the camera mounting mode.

1. Click **Camera > Camera > Fisheye**.

IP Addr.	Mount	Angle of View(°)	Fisheye Mode	Model	Edit
206.2.22.150	Ceiling	0	Fisheye	IPC868ER-VF18-B	

2. Click  under **Edit**. The Fisheye window appears.
3. Select a correct mounting mode and complete other settings accordingly.
4. Click **OK**.

Dewarping















NOTE: Dewarping is available in live view and playback (in normal and corridor playback modes). The operations are similar. The following describes dewarping in live view.

Click **Fisheye Mode** on the window toolbar. The figure below appears. Set mounting mode and

display mode.



Three mounting mode are available: ceiling, wall, desktop. Ceiling and desktop mounting modes use the same dewarping method.

Mounting Mode	Display Mode	Description
Ceiling Mount 		Original Image
		360° Panoramic+1PTZ
		180° Panoramic
Desktop Mount 		Fisheye+3PTZ
		Fisheye+4PTZ
		360° Panoramic+6PTZ
		Fisheye+8PTZ
Wall Mount 		Original Image
		Panoramic
		Panoramic+3PTZ
		Panoramic+4PTZ
		Panoramic+8PTZ

Operations: Take Ceiling Mount and Fisheye+3PTZ as an example:

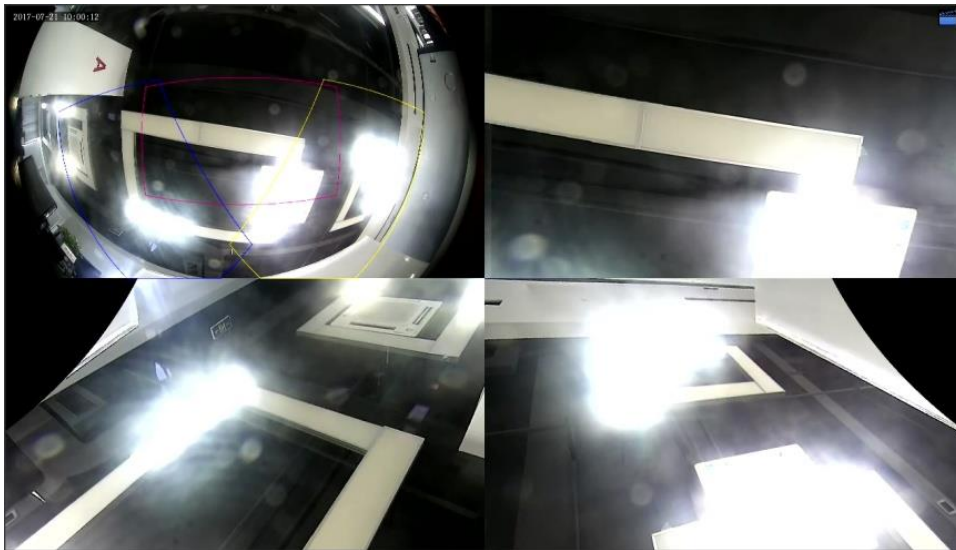

On a PTZ image, drag the mouse to rotate the image or use the scroll wheel to zoom in or out. A box appears on the fisheye image as the image rotates, and as you drag the box or move the scroll wheel on the fisheye image, the corresponding PTZ image rotates or zooms in or out as well.

Advanced Functions

Change the password of connected IP cameras or restore the factory default settings under **Camera > Camera > Advanced**.

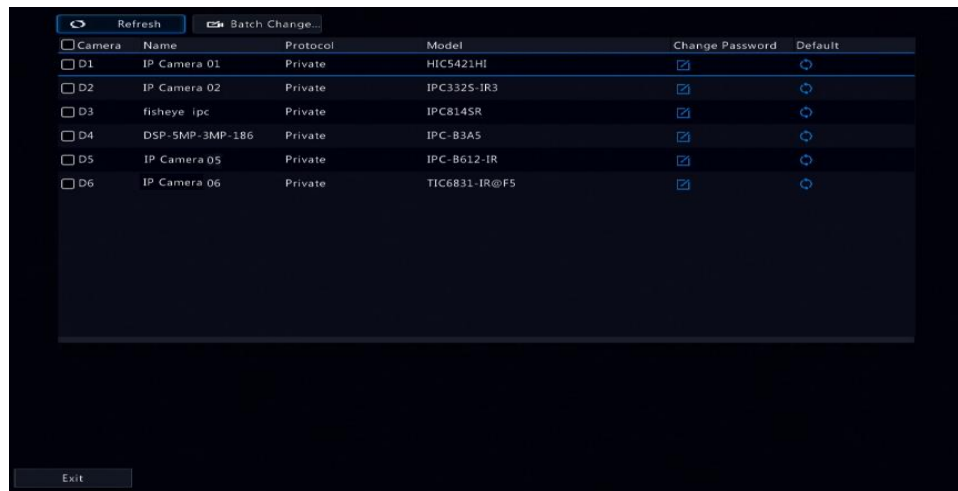

NOTE: Changing of camera password is available for certain models only.

Change Camera Password

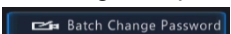
- To change the password of a single camera, select the target camera, and click , enter the new password, then click **Confirm**.
- To change the password of cameras in batch, select the target cameras, and click . Enter the new password, then click **Confirm**.

NOTE:

- Select the checkbox of the Use Admin Password to change the camera password to the admin's password of the NVR.
- You can check if the password has been successfully changed on the **Status** window.

Restore Default Settings

Click , then click **OK** in the pop-up window, then the camera's default settings will be restored.

OSD Configuration

On Screen Display (OSD) are characters displayed with video images on the screen, for example, camera name, date and time.

NOTE: Feature available only in Z camera models.

- Click **Camera > OSD**; or click  on the preview window toolbar.

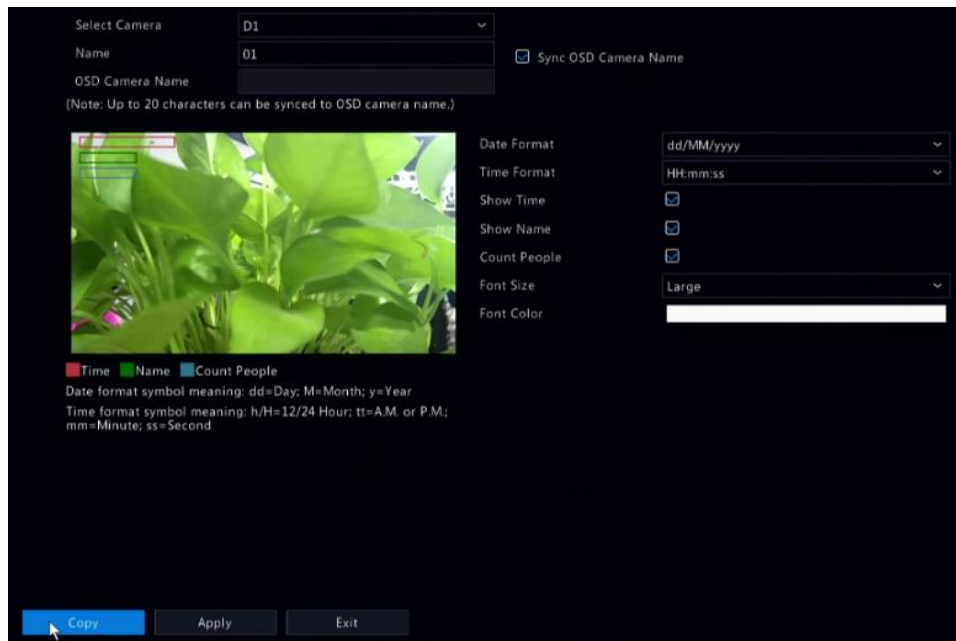

- Select the desired camera.
 - Set the camera name you want to display on the screen. Enable **Show Name** first, and set the OSD camera name as needed.
 - If the camera name is less than 20 characters, and camera name and **OSD Camera Name** (i.e., the camera name you want to overlay on video image) are same:
 - Select **Sync OSD Camera Name**, then the OSD name will be synchronized with the camera name. This function is enabled by default.
 - Enter the camera name in the **Name** field. The name will be displayed on video image
- NOTE:** If the camera name exceeds 20 characters, only the first 20 characters will be used as the OSD camera name.
- If the camera exceeds 20 characters, and you want to overlay a different camera name on the video image:
 - Deselect **Sync OSD Camera Name**.

- ii. Enter the camera name in the **Name** field.
 - iii. Enter the OSD camera name.
- Set time to display. Select **Show Time**, and select the date and time formats.
 - Set font size and color as needed.
- NOTE:** You may click **Copy** to apply the same settings to other camera.
- Click **Apply** to save the settings.

Image Configuration

1. Click **Camera > Image**.
2. Select the desired camera and scene.

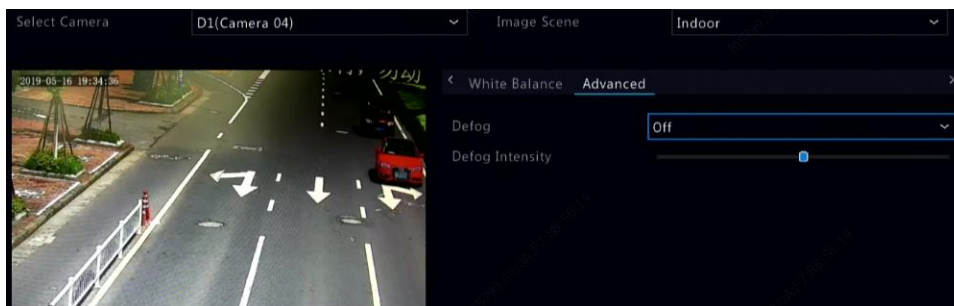

3. Adjust settings on the tabs as needed to achieve optimal images. See the following sections for detailed information.

NOTE:

- A scene can be selected only when supported by the IP camera.
- To restore default image settings, click **Default** in the lower right corner. This function is available only when the camera is connected to the NVR via the private protocol.
- Image settings apply to both live and recorded videos.

Smart Illumination

NOTE: This function is available on select models only.

Click the Smart Illumination tab and set the parameters.

1. Click the **Smart Illumination** tab.
2. Check **Smart Illumination** to enable this function.
3. Adjust the settings as needed. Some important parameters are described in the table below.

Parameter	Description
Smart Illumination	Check to enable smart illumination.
Illumination Mode	Select the lighting type from the drop-down list. Options vary depending on camera model.
Control Mode	Select the control mode from the drop-down list. Options vary depending on camera model: <ul style="list-style-type: none"> • Road Preset: The near and far illumination brightness will be preset according to the common road scenario. • Park Preset: The near and far illumination brightness will be preset according to the common park scenario. • Manual: Controls the near and far illumination brightness manually. Scroll the bars to adjust.

Image enhancement

1. Click the **Image Enhancement** tab.
2. Adjust the settings as needed. Some important parameters are described in the table below.

Parameter	Description
Brightness	The greater the value, the brighter the images appear.
Saturation	The amount of color in a specified hue.
Contrast	The degree of difference between the lightest (white) and darkest (black) parts of an image. Setting a greater value increases contrast.
Hue	Purity of colors in an image.
Sharpness	Contrast of boundaries of objects in an image.
Noise Reduction	Reduce noises in images to improve image quality.
Image Rotation	<ul style="list-style-type: none"> • Normal: Displays images without rotation. • Flip Vertical: Displays images flipped vertically. • Flip Horizontal: Displays images flipped horizontally. • 180°: Displays images flipped vertically and horizontally. • 90° CW and 90° CCW: Display images in corridor format. The camera must be installed correctly (rotated 90° clockwise or counterclockwise).

Exposure

1. Click the **Exposure** tab.

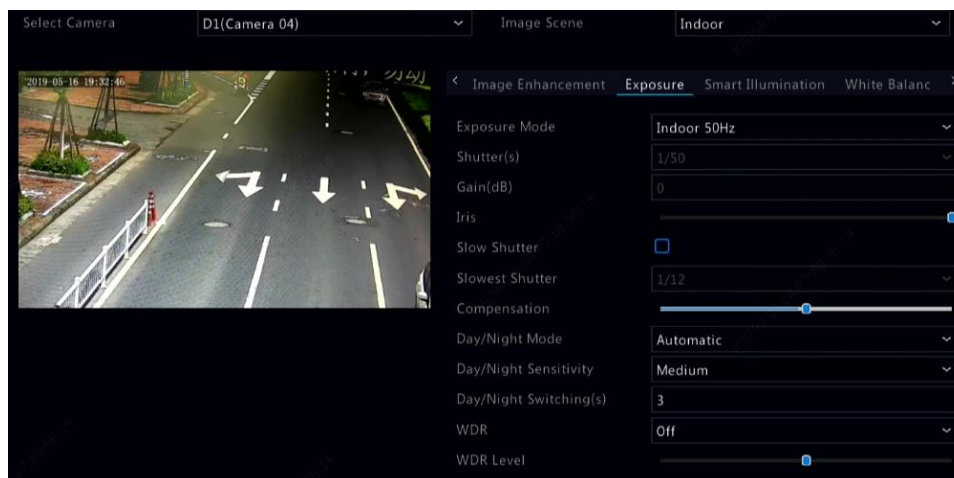

2. Adjust the settings as needed. Some important parameters are described in the table below.

Parameter	Description
Exposure Mode	Select the correct exposure mode to achieve the desired exposure effect.
Shutter(s)	Shutter is used to control the light that comes into the lens. A fast shutter speed is ideal for scenes in quick motion. A slow shutter speed is ideal for scenes that change slowly.
Gain (dB)	Control image signals so that the camera can output standard video signals in different light conditions.
Iris	Adjust iris opening of the lens to control the amount of incoming light.
Slow Shutter	Improves image brightness in low light conditions.
Slowest Shutter	Set the slowest shutter speed for the camera during exposure.
Compensation	Adjust the compensation value as required to achieve the desired image effects.
Day/Night Mode	<ul style="list-style-type: none"> Automatic: In this mode, the camera can automatically switch between night mode and day mode according to the ambient lighting condition to output optimum images. Night: The camera outputs high-quality black and white images according to the ambient lighting condition. Day: The camera outputs high-quality color images according to the ambient lighting condition.
Day/Night Sensitivity	Light threshold for switching between day mode and night mode. A higher sensitivity value means that the camera is more sensitive to the change of light and is therefore more easily to switch between day mode and night mode.
Day/Night Switching(s)	Set the length of time before the camera switches between day mode and night mode after the switching conditions are met.
WDR	Enable WDR to ensure clear images in high contrast conditions.

Parameter	Description
WDR Level	After enabling WDR, you can improve image quality by adjusting the WDR level.

White balance

1. Click the **White Balance** tab.

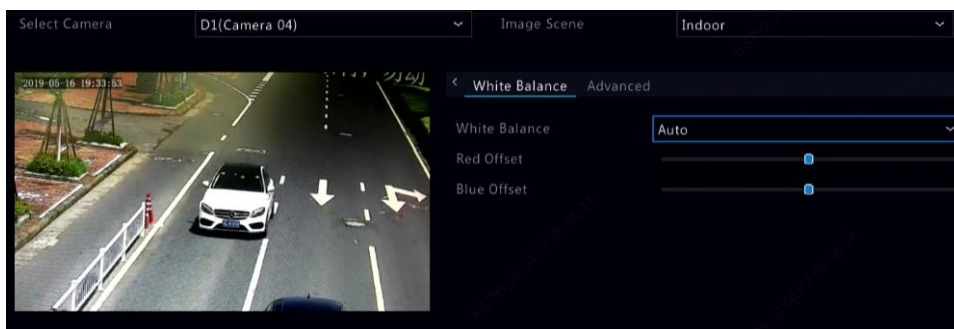

2. Adjust the settings on this tab. Some important parameters are described in the table below.

Parameter	Description
White Balance	Adjust the red or blue offset of the image: Auto: The camera adjusts the red or blue offset automatically according to the lighting condition (the color tends to be blue). Finetune: Allow you to adjust the red or blue offset manually.
Red Offset	Adjust the red offset manually.
Blue Offset	Adjust the blue offset manually.

Advanced settings

1. Click the **Advanced** tab.
2. Use defog to improve image quality in foggy days.

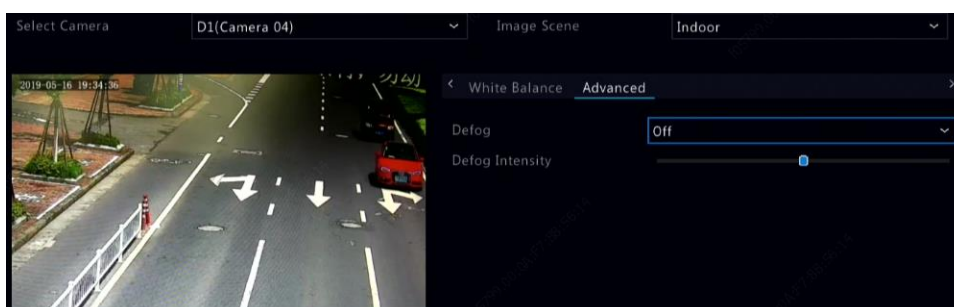

Privacy Mask Configuration

A privacy mask is an area of solid color covering certain parts of the monitored area. Privacy mask protects specified areas of images from being viewed and recorded. Multiple mask areas are allowed.

1. Click **Camera > Privacy Mask**.
2. Select the desired camera, select **Enable Privacy Mask**, click Add Area and then use the mouse to specify areas to mask. Up to eight (8) areas are allowed, however, the number of allowed areas may vary with device model. The areas are differentiated by different colors.

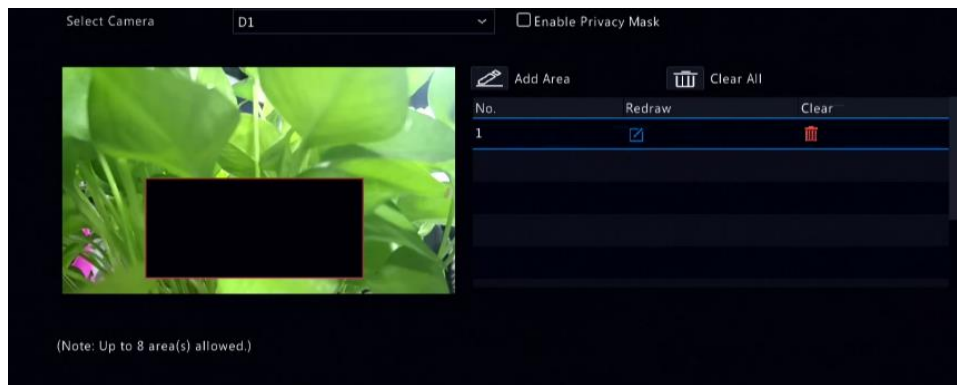

3. (Optional) To clear a mask area, click .
4. Click **Apply** to save the settings.









PTZ Control

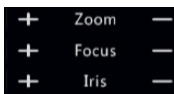

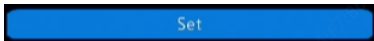
PTZ (pan, tilt and zoom) control is applicable to PTZ cameras only and may vary depending on the functions and protocols supported by the PTZ cameras. Refer to PTZ camera specifications for more details.

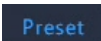
PTZ Control Window and PTZ Management Window

1. Click  on the window toolbar. The **PTZ Control** window appears. See [PTZ Control Window Buttons](#) for detailed descriptions.
2. Click the **Set** button. The **PTZ Management** window appears (can also be opened by clicking **Camera > PTZ**).

PTZ Control Window Buttons

Button	Description
	Control the rotation direction of the PTZ camera or stop rotation.
	Adjust the zoom, focus, and iris of the PTZ camera. NOTE: You can also zoom in or out using the scroll wheel on your mouse.
	Control the rotation speed of the camera. 1 means the slowest, and 9 means the fastest.
	Click to display the PTZ Management window.
	Turn on/off the light. Turn on/off the wiper. Use 3D positioning. Turn on/off the heater. Turn on/off the function to remove snow. Turn on/off PTZ shortcut operations. NOTE: <ul style="list-style-type: none"> • Check that the 3D positioning, heater and snow removal functions are supported by the camera before using. • Use 3D positioning to zoom in or out. Dragging from top down zooms in. Dragging the other way zooms out.
	Preset button.
	Call a preset so the PTZ camera goes to the preset position. Delete a preset NOTE:  and  are displayed for saved presets only.
	Preset patrol, recorded patrol and auto guard. For detailed information, see Setting a Preset Patrol , Setting a Recorded Patrol , and Setting Auto Guard .



Button	Description
 	Start or stop.

Setting and Calling a Preset

A preset position (preset for short), is a saved view used to quickly steer the PTZ camera to a specific position. A preset consists of the following settings: pan and tilt positions, zoom, focus, and iris.

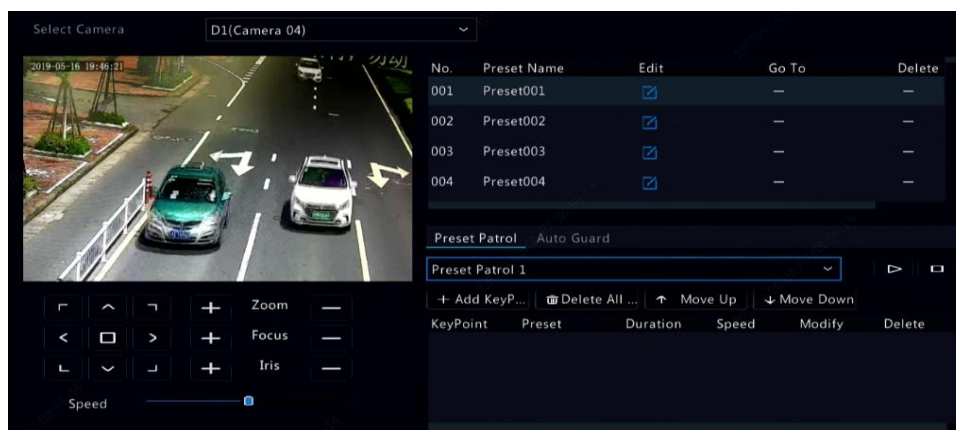
1. Access the **PTZ Management** window. For the detailed steps, see [PTZ Control Window and PTZ Management Window](#).



2. Add presets.
 - a. Click the directional buttons to steer the PTZ camera to the desired position.
 - b. Adjust the zoom, focus, and iris as needed.
 - c. Select a preset number not in use, and then click  under **Edit**.
 - d. Repeat the above steps to add all the presets.
3. To call a preset, click  for the corresponding number. The camera rotates to the preset position.







NOTE: Presets can also be triggered by alarms. See [Alarm-Triggered Actions](#) for details.

Setting a Preset Patrol

Set the PTZ camera to patrol by presets (go from one preset to the next in specified order). You need to set presets first and then select some as keypoints. Up to four patrol routes (Preset Patrol 1, 2, 3 and 4) are allowed for each PTZ camera, and each patrol route can have up to eight presets (keypoints). After setting presets, follow the steps to set a preset patrol. The following takes preset patrol 1 as an example.

1. In the **PTZ Management** window, click . A window is displayed as follows.

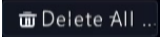

2. Select a preset from the drop-down list, set the duration (time the camera stays at the preset, unit: second), and then set the rotation speed (1: slowest, 9: fastest). Click **OK** to save the settings. The preset is added as a keypoint.
3. Repeat the above steps to add all presets (keypoints), and adjust the sequence of these presets by clicking  or . Modify or delete a preset by clicking  or . Clicking  will delete all the added keypoints.
4. After completing the configuration, click **Apply** to save the settings. Now keypoints for preset patrol 1 is complete.
5. Click  right to the drop-down list to start preset patrol 1. To stop, click .

NOTE: The duration ranges from 0 to 1800 seconds (default: 10). The rotation speed ranges from 1 to 9 levels (default: 5).



Setting a Recorded Patrol

This function requires the camera's support. The drop-down list and the buttons on the right are hidden if this function is not supported by the camera. Currently only one recorded patrol route is allowed.

Record a patrol, including the patrol route, the time that the camera stays at a certain direction, rotation speed, zoom, focus and focus.

1. Click  to start recording. Steer the camera to the desired directions, adjust the zoom, focus, iris as needed during the process.



2. Click  to stop recording. All the patrol actions have been recorded.
3. To start the recorded patrol, click . Click  to stop.

Setting Auto Guard

Use auto guard so the PTZ camera automatically operates as configured if no operation is performed by any user during a certain time period. Auto guard avoids situations where the camera is left to monitor incorrect scenes by user's negligence.

This function requires the camera's support. The **Auto Guard** tab is hidden if it is not supported.

1. Click **Auto Guard** and then select **Enable**.
2. Select the desired mode from the drop-down list and then complete other settings accordingly. Click **Apply** to save the settings.

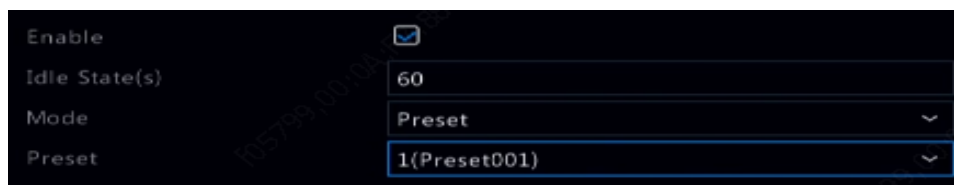

Recording and Snapshot

Video recording has different levels of priority, which from high to low is: event recording, manual recording, and scheduled recording.

Encoding Settings

Recording

The parameters and options displayed may vary with camera model and version. Some functions may be unavailable if the camera version is too low. In this case, you need to upgrade the camera first.

- Click **Camera > Encoding**.

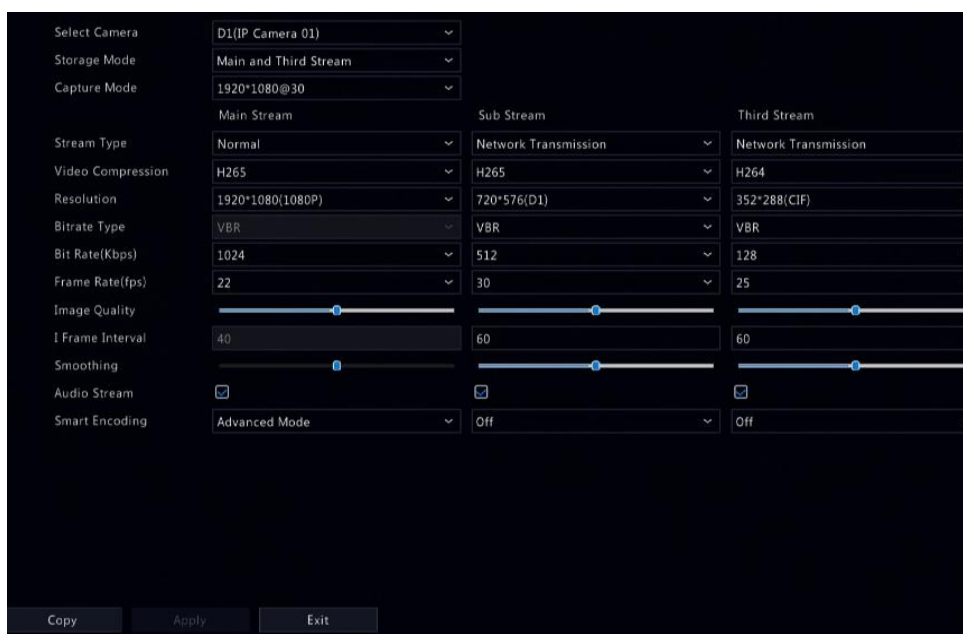

- Select the camera and then edit settings as needed. Some parameters are described in the table below.

Encoding Settings

Parameter	Description
Storage Mode	Main Stream Sub Stream By default, the main stream is used for storage.
Capture Mode	Combinations of resolutions and frame rates. NOTE: This parameter is effective only when the camera is connected to the NVR via private protocol.
Stream Type	<ul style="list-style-type: none"> • Normal: Main stream that is intended for scheduled recording. • Event: Main stream that is intended for recording triggered by events such as alarm inputs or motion detection alarms.

Parameter	Description
	<ul style="list-style-type: none"> Sub Stream: Low resolution video that is intended for local or remote real-time monitoring.
Video Compression	Video compression standard, for example, H.264, H.265. The listed options depend on the standards supported by the camera. NOTE: When connecting ONVIF cameras, only H.264 and H.265 are the available compression.
Resolution	Image resolution.
Bitrate Type	<ul style="list-style-type: none"> CBR: Constant Bit Rate (CBR) is used to maintain a specific bit rate by varying the quality of video streams. CBR is preferred when limited bandwidth is available. The disadvantage is that video quality will vary and may decrease significantly with increased motion in the scene. VBR: When using Variable Bit Rate(VBR), video quality is kept as constant as possible, at the cost of a varying bit rate, and regardless of whether or not there is motion in the image. VBR is ideal when high quality is a requirement, especially when there is motion in the picture.
Bit Rate (Kbps)	Number of bits transferred per second. Select a value or select Custom and then set a value as needed.
Range	Bit rate range. Currently the range is fixed.
Frame Rate (fps)	Number of frames per second. NOTE: Due to automatic rounding of numbers, the frame rate value may have 1-2 fps difference on what is shown on the OSD.
Image Quality	This parameter is effective only when Bitrate Type is set to VBR . Six levels are provided.
I Frame Interval	Number of frames between two adjacent I frames.
I Frame Range	Range of I frames. Currently the range is fixed.
Smoothing	Use the slider to control the sudden increase of bit rate.
Audio Stream	Enable or disable audio stream.
Smart Encoding	The advanced mode achieves higher compression ratios.

- (Optional) Click **Copy** to apply some current settings such as bit rate and frame rate to other cameras.
- Click **Apply** to save the settings.

Snapshot

Set resolution, image quality and snapshot interval for snapshots taken according to schedule or triggered by an event.

1. Click **Camera > Snapshot**.
2. Set the parameters as needed.



Parameter	Description
Snapshot Type	Scheduled snapshot uses the Normal type of schedule. Event-triggered snapshot is triggered by an event such as an alarm input and a motion detection alarm. NOTE: Settings effective to event-triggered snapshot also apply to manual snapshot.
Resolution	Snapshot resolution.
Image Quality	High, Medium or Low resolution.
Snapshot Interval	The time interval between two snapshots.

3. Click **Apply** to save the settings.

Draw or Edit a Schedule

Make a recording or snapshot schedule by drawing (pressing and dragging) or by editing (using the **Edit** button). The operations for recording and snapshot are similar, so this section only describes how to make a recording schedule.

1. Click **Storage > Recording**.
2. Select the camera from the list. Schedule is enabled by default. If it is disabled, select to enable it.
3. Set **Pre-Record** and **Post-Record** as needed.
4. (Applicable to some NVR models) To save a redundant copy of recordings, select **Enable Redundant Recording** and configure a redundant hard disk (see [Disk Management](#) for details).



5. Click a color icon on the right under the **Edit** button and then draw a schedule on the left. You may also click **Edit** and set schedule details in the **Edit Schedule** window.

NOTE: When editing a schedule, you may clear the **All Day** check box and set up to eight different periods for each day. To apply the settings to other day(s), select the day(s) right to **Copy To**.

6. Click **Apply**.
7. (Optional) Click **Copy** to apply the same settings to other cameras.

Scheduled Recording and Snapshot

Scheduled Recording

Scheduled recording records video according to the set schedule and it is different from manual recording and alarm-triggered recording. A 24×7 recording schedule is enabled by default and may be edited as needed to record video in specified periods only.

See [Draw or Edit a Schedule](#) for the detailed steps. Make sure the schedule type is **Normal**. The set schedule appears in blue, which stands for scheduled recording.

Scheduled Snapshot

Configure scheduled snapshot under **Storage > Snapshot**. Scheduled snapshot is similar to scheduled recording (see [Scheduled Recording](#) for details). Make sure the schedule type is **Normal**.

Motion Detection Recording and Snapshot

When enabled, a motion detection alarm occurs if an object inside the detection area moves to a certain extent. Motion detection alarms can trigger actions including recording and snapshot.



Motion Detection Recording

1. Click **Alarm > Motion**.
2. Select the camera from the list, and then select the check box to enable motion detection.

NOTE:

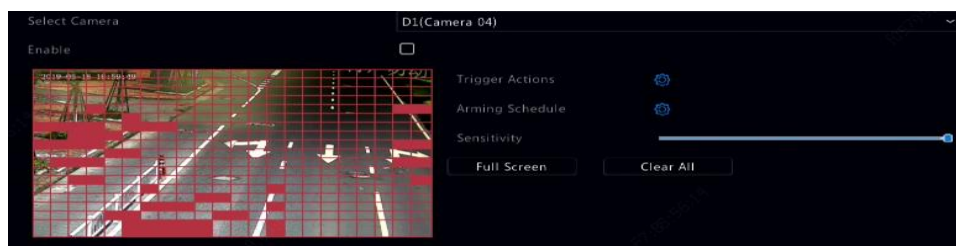
- Motion detection is enabled on the NVR by default. Unless modified, the detection area covers the full screen, and recording is triggered only for the current camera. The settings remain if you disable motion detection and then enable it.
 - An alarm icon appears in the upper right corner when motion is detected.
3. In the preview window on the left side, click and drag your mouse to specify a motion detection area (red grid). Use the sliders to adjust detection sensitivity, target object size, and duration.



4. Configure motion detection recording: click  to Trigger Actions, click the Recording tab, select the desired camera, and then click **OK**.
5. (Optional) Configure an arming schedule (time when actions will be triggered): click  to **Arming Schedule** and then set time periods as needed.
6. Set a recording schedule under **Storage > Recording**. For the detailed steps, see [Draw or Edit a Schedule](#). Make sure the schedule type is **Motion**. The set schedule appears in green, which stands for motion detection recording. The following figure shows an example.

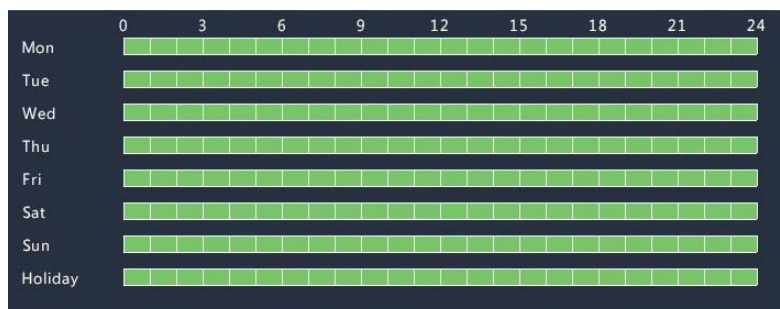

Motion Detection Snapshot

Motion detection snapshot is similar to motion detection recording. You need to enable and configure motion detection alarm first (see steps 1 to 3 in [Motion Detection Recording](#) for details), and then proceed with the following steps.

1. Set motion detection snapshot under **Alarm > Motion**: click  to **Trigger Actions**. In the window displayed, click the **Snapshot** tab, select the desired camera, and then click **OK**.
2. Set a snapshot schedule under **Storage > Snapshot**. For the detailed steps, see [Draw or Edit a Schedule](#). Make sure the schedule type is **Motion**.

Alarm Triggered Recording and Snapshot

Set input alarms to trigger recording and snapshot. See [Alarm Input and Output](#) for more details.

Alarm Triggered Recording

1. Click **Alarm > Input/Output > Alarm Input**.
2. Set alarm input: click  for the desired camera. In the window displayed, select **Enable**, select N.O. (normally open) or N.C. (normally closed) trigger mode, and then click **OK**.



NOTE: To apply the same settings to other camera(s), click **Copy** and then select the desired camera(s).

3. Set alarm triggered recording: click  under **Trigger Actions**. In the window displayed, click the **Recording** tab, select the desired camera, and then click **OK**.
4. Set a schedule under **Storage > Recording**. For the detailed steps, see [Draw or Edit a Schedule](#). Make sure the schedule type is **Alarm**. The set schedule appears in red, which stands for alarm-triggered recording. The following shows an example.

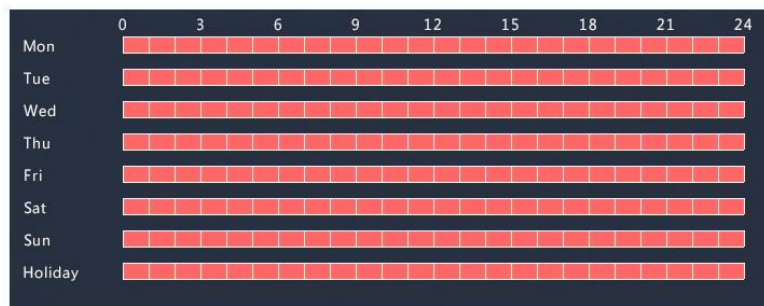

Alarm Triggered Snapshot

Alarm triggered snapshot is similar to alarm triggered recording. You need to enable and configure alarm input first (see steps 1 to 2 in [Alarm Triggered Recording](#) for details) and then proceed with the following steps.

1. Set alarm triggered snapshot: Click  under **Trigger Actions**. In the window displayed, click the **Snapshot** tab, select the desired camera, and then click **OK**.
2. Set a snapshot schedule under **Storage > Snapshot**. For the detailed steps, see [Draw or Edit a Schedule](#). Make sure the schedule type is **Alarm**.

Manual Recording and Snapshot

Manual Recording

Right click on the preview window, select **Manual** in the shortcut menu. Click the **Manual Recording** tab, select the desired camera and then click **Start**. To stop manual recording, select the camera and then click **Stop**.

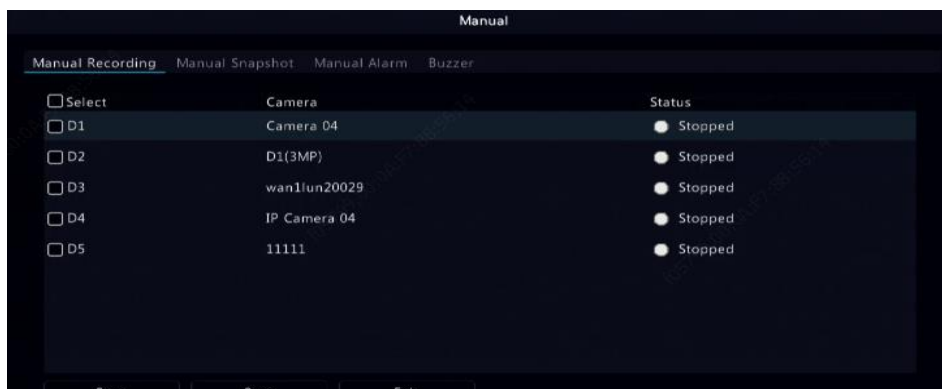

Manual Snapshot

Manual snapshot is similar to manual recording. Right click and select **Manual > Manual Snapshot**, select the desired camera, and then click **Start**. Click **Stop** to stop.

Holiday Recording and Snapshot

Holiday recording and snapshot allows you to specify certain time periods as holidays for scheduled recording and snapshot. First you specify certain date(s) as holidays, and then configure recording or snapshot schedules on these days.

Holiday Recording

1. Click **System > Time > Holiday**.
2. Click the **Add** button in the lower right corner. The **Holiday** window is displayed. Complete the settings including the holiday name, start and end dates. By default a holiday is enabled when added and does not repeat.

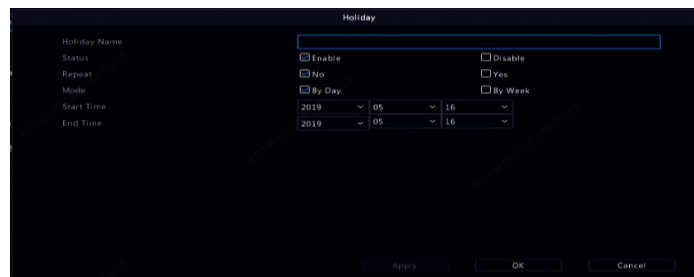

3. Click **OK**. The holiday appears in the list.
4. Click **Storage > Recording** and then set a recording schedule as described in [Draw or Edit a Schedule](#). Make sure **Holiday** is selected in the **Select Day** drop-down list. In the following example, motion detection recording is enabled on the set holiday.

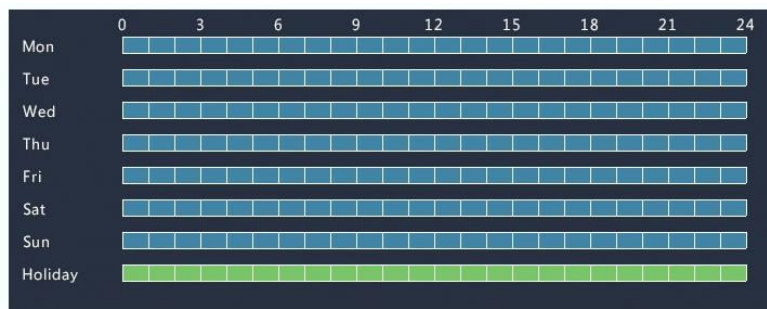

Holiday Snapshot

Holiday snapshot is similar to holiday recording. First you set holidays under **System > Holiday**, and then configure a snapshot schedule under **Storage > Snapshot**. Set a snapshot schedule as described in [Scheduled Recording](#). Make sure **Holiday** is selected from the **Select Day** drop-down list.

Other Recording and Snapshot Types

Other recording and snapshot types:

- Event: Including the types below and VCA. Any of these types will trigger event recording/snapshot.
- Motion detection AND alarm triggered (M and A for short): recording or snapshot is triggered only when a motion detection alarm AND an input alarm occur simultaneously.
- Motion detection OR alarm triggered (M or A for short): recording or snapshot is triggered when a motion detection alarm OR an input alarm occurs.

When you choose an Event type of recording or snapshot, make sure you have enabled the corresponding alarm function and configured alarm-triggered recording/snapshot. The configuration steps are similar. See [Motion Detection Recording and Snapshot](#) for more details.

Playback

Instant Playback

Instant playback plays the video recorded during the last 5 minutes and 30 seconds. If no recording is found, it means there is no recording during this period.







1. Click the desired window, and then click  on the toolbar to start instant playback.
2. You may drag the slider to control the progress. Pause and resume as needed.



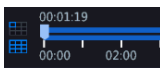









NOTE: Once the slider is dragged to an earlier timeline, the playback may not sync and continue with the current timeline. Exit the Playback screen first and then go back and continue with the Live Playback.

Playback Toolbar

Playback Toolbar Buttons

Button	Description
	Show playback progress. NOTE: <ul style="list-style-type: none"> • A small window displaying video of the selected window is displayed as you drag the slider, helping locate the part of the video you want to view. • The first progress bar indicates playback progress of the video playing in the highlighted window. The second indicates the overall playback progress for all the selected cameras.
	Timeline.
	Zoom in or out on the timeline. NOTE: Alternatively, scroll your mouse wheel.
	Play, pause, stop, and reverse.
	Rewind or forward 30 seconds.
	Slow down or speed up.

Button	Description
	NOTE: Click  to restore the normal playback speed after clicking  , and vice versa.
	Forward by frame.
	Start or stop clipping video.
	Take a snapshot. The window borders will flash white.
	Lock.
	Manage files (clips, snapshots, locked files, tags).
	Zoom in on images. For more details, see Zoom .
	Turn off/on audio.
	Adjust sound volume for the current window.

Playback by Camera and Date

Use this method to play recordings found by camera and date.

1. Click on the preview window, then right-click the mouse and then choose **Playback** to start playback.

NOTE: In the playback window, you can select multiple cameras for synchronous playback. Clicking **Max. Camera** selects the maximum number of cameras allowed, and clicking **Close All** stops playback for all cameras. The performance varies with NVR model.

2. Select the desired date on the calendar and then click  to start playback. Double-clicking the date will start playback directly.



NOTE:

- The calendar uses different flags to indicate different recording types. No flag means no recording. The blue flag means normal recording. The red flag means event-triggered recording.

- In the drop-down list, right click to playback mode: **HD** means video recorded with the main or sub stream; **SD** means video recorded with the third stream.

Playback in Corridor Mode



Play recordings in corridor mode in multiple windows.

1. In the playback window, select **Corridor** from the drop-down list in the upper left corner.
2. Select cameras and then double-click the desired date to start playback.

Playback by Tag

Add tags named with keywords such as event name and location to a recording and use tags to quickly locate the part of the video you need during playback.

Adding a Tag

1. Right-click and then click choose **Playback**.
2. Click  on the window toolbar, and then set the tag name.
3. To manage the added tags, click , and then rename or delete tags as needed.

Playback by Tag

1. In the playback window, click **Video Retrieval**, select **Tag Search** from the drop-down list in the upper left corner.
2. Select cameras, set the time period, enter keywords, and then click **Search**. Search results, if there are any, are displayed with names of cameras and tags.
3. Click  for the desired tag to start playback. You may use the **Start Before** and **Stop After** drop-down lists to set when the tagged video starts and ends.

Playback by Motion Detection

Search for and play recordings triggered by motion detection during a specified time period.

NOTE: Make sure motion detection is enabled and alarm-triggered recording has been configured before you use this function. See [Motion Detection Recording and Snapshot](#) and [Alarm Triggered Recording and Snapshot](#) for details.

1. In the playback window, click **Video Retrieval**, select **Motion** from the drop-down list in the upper left corner.
2. Select the desired camera, set the time period, and then click **Search**.
3. Click  for the desired recording to start playback.

Playback by Video Loss

Search for and play recordings triggered by video loss during a specified time period.





NOTE: Make sure video loss alarm is enabled and alarm-triggered recording has been configured before you use this function. See [Video Loss](#) and [Alarm-Triggered Actions](#) for details.

1. In the playback window, click **Video Retrieval**, select **Video Loss** from the drop-down list in the upper left corner.
2. Select the desired camera, set the time period, and then click **Search**.
3. Click  for the desired recording to start playback.

Playback by Smart Search



This function provides an efficient way to review recordings containing smart search results such as detected motions. In smart playback mode, the system analyzes recordings for smart search results. If such results are detected, the progress bar is highlighted in green, and the video plays at the normal speed, allowing you enough time to catch details. The video containing no such results plays at 16x speed to save time.

1. In the playback window, select **Smart** from the drop-down list in the upper left corner.
2. Click  for the desired camera to start smart playback.

3. Click . The smart search window is displayed. By default, the full screen is the smart search area. To clear all, click , to restore the full-screen search area, click .
4. Set smart search rules, including detection region and detection sensitivity.
5. Click  to start search. To quit, click .

Playback by External File

Use this function to play recordings stored in an external storage device, for example, a USB drive or a portable USB hard drive.

1. In the playback window, click  on the screen toolbar.
2. Click **Refresh** and then wait for the NVR to read the external storage device.
3. Select the desired recording file and then click  to start playback.

Playback by Image



Specify an image type (for example, Normal or Motion) to search for and play images from one or more cameras during a specified time period.

1. In the playback window, select **Video Retrieval**, select **Picture Search** from the drop-down list in the upper left corner.
2. Select a type from the **Type** drop-down list in the upper right corner.
3. Select the desired camera(s), set the desired time period, and then click **Search**.
4. Click the desired file to start playback.

File Management

File management allows you to manage video clips, tags, snapshots taken during playback, and lock or unlock files.





1. Take snapshot during playback.

- (1) On the playback page, play the recording until the desired image appears.
- (2) Click  in the playback window to take a snapshot.
- (3) Click  and then click the **Playback Image** tab to view the snapshot.
- (4) Select the desired image file(s) and then click **Backup** to save them to the storage device.

NOTE: The image resolution depends on the resolution from the output interface and the number of windows displayed when the snapshot is taken.

2. Lock files.

Use this function to lock a recording file so it will not be overwritten. To lock a recording file will prevent all the files stored in the same disk partition (254.4 MB in size) from being overwritten.

- (1) Play the recording you want to lock.
- (2) Click  in the playback window.
- (3) Click  and then click the **Locked File** tab to view the locked file. To unlock a file, click , and the icon changes to . To back up a file, select the file and then click **Backup**.

Backup

Recording Backup

Backup, also known as recording backup, is the process of querying video stored on a hard disk of the NVR and then saving the recording to a USB storage device as a file.

Recording backup has the following conditions:

- Format the partition of the USB storage device in FAT32 or NTFS format; connect the storage device correctly to the NVR.
- Permission is required.
- The recording to back up is stored on a hard disk of the NVR.

NOTE: By default, recordings are backed up as MP4 files.

Normal Backup

1. Click **Backup > Recording**. All cameras are selected by default.
2. Set search conditions and then click **Search**. Search results are displayed.

NOTE: You can lock/unlock and play recording files in this window.

3. Select the desired recording(s) and then click **Backup**.
4. Select a destination in the USB storage device and then click **Backup**. The recording(s) will be saved to the specified directory.

NOTE:

- You may want to create a new folder for the recording(s) by clicking **New Folder**.
- If the connected storage device has a capacity that is greater than 2TB, clicking **Format** will format the device to NTFS file system. If the capacity is 2TB or less, the device will be formatted to FAT32 or NTFS. Only certain devices can format a storage that has a greater capacity than 2TB.
- A progress bar (e.g., **Exporting X/Y**) is displayed to indicate the progress, where *X* indicates the current number being backed up, and *Y* indicates the total number of recordings. To cancel the operation, click **Cancel**.
- A backup file is named in this format: *camera name-recording start time*.file extension. For example, Ch9-20150630183546.mp4.

Video Clip Backup

A recording can be clipped and saved to a USB storage device.



1. Open the playback window. For the detailed steps, see [Playback](#).
2. After playback starts, click  on the playback toolbar to clip videos.
3. Click  and then click the **Video Clip** tab to view video clips.
4. Select the desired video clip(s) and then click **Backup**.
5. Select a destination in the USB storage device and then click **Backup**. The selected video clips are saved to the specified directory.

Image Backup

The default format of image backup is JPG.

1. Click **Backup > Image**.
2. Set search conditions and then click **Search**. Search results are displayed.

NOTE: The image resolution depends on the resolution from the output interface and the number of windows displayed when the snapshot is taken.

3. Select the desired file(s) and then click **Backup**.
4. Select a destination in the USB storage device and then click **Backup**. The selected files are saved to the specified directory.

Alarm

Alarm Input and Output

Alarm Input

1. Click **Alarm > Input/Output > Alarm Input**.
2. Click  for the desired camera. In the **Alarm Input** window, select **Enable** to enable alarm input.
3. Select the normally open (N.O.) or normally closed (N.C.) trigger mode, and then click **OK**.



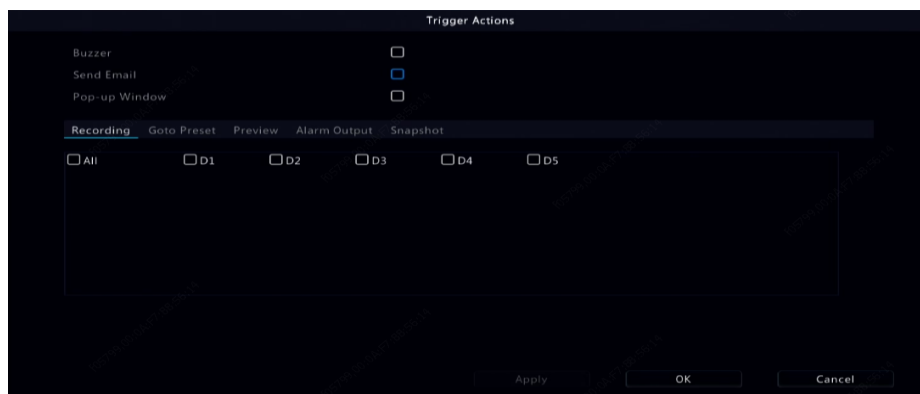

4. Click  under **Trigger Actions** and then set action(s) to trigger. For more details, see [Alarm-Triggered Actions](#).



NOTE:

- The default schedule is 24x7. You may change it, as needed, and set up to eight (8) different periods for each day. Time periods cannot overlap.
- To apply the same arming schedule to other days, select the intended days, right-click on **Copy To**.
- To apply the same settings to the cameras, click **Copy**, select the cameras, and then click **OK**.

Alarm Output

1. Click **Alarm** > **Input/Output** > **Alarm Output**.
2. Click  under **Edit** for the desired camera, and then set the default status and duration. After you have completed the settings, click **OK**.
3. Click  under **Arming Schedule** and then set the time when actions will be triggered.

NOTE: To apply the same settings to other cameras, click **Copy**, select cameras, and then click **OK**.

Motion Detection

When enabled, a motion detection alarm occurs if an object inside the detection area moves to certain extent, and an alarm icon appears in the upper right corner.

Motion detection is enabled on the NVR by default. Unless modified, the detection area covers the full screen, and recording is triggered only for the current camera. The settings remain if you disable motion detection and then enable it.

1. Click **Alarm > Motion**.
2. Select the desired camera and then select **Enable** to enable motion detection.
3. Use the mouse to draw a detection area, and drag the slider to set detection sensitivity, target object size, and duration. The higher the sensitivity, the more likely a moving object will be detected.

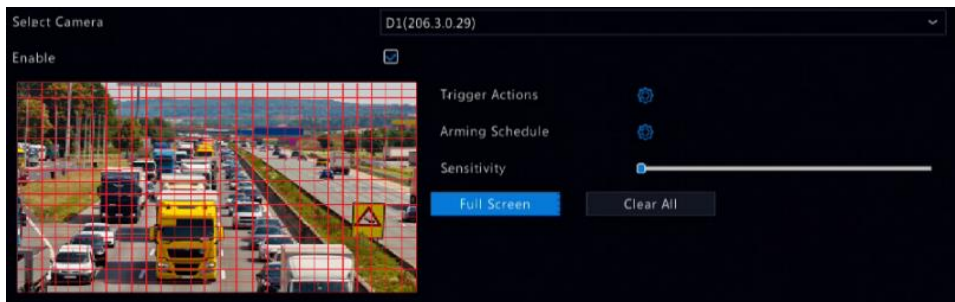

4. Click  right to **Trigger Actions** and set action(s) to trigger. For more details, see [Alarm-Triggered Actions](#).

NOTE:

- The number of cameras that can be connected may vary with NVR model.
- Actions that can be triggered may vary with alarm type.

5. (Optional) Click  right to **Arming Schedule** and then set the time when actions will be triggered.

NOTE:

- The default schedule is 24×7. You may change it as needed and set up to eight different periods for each day. Time periods cannot overlap.
- To apply the same arming schedule to other days, select the intended days right to **Copy To**.



6. Click **Apply** to save the settings.
7. (Optional) Click **Copy** to apply the same settings to other cameras.

Tampering Detection

A tampering detection alarm occurs when the camera lens is covered.

1. Click **Alarm > Tampering**.
2. Select the desired camera and then select **Enable** to enable tampering detection.





3. Click  right to **Trigger Actions** and set action(s) to trigger. For more details, see [Alarm-Triggered Actions](#).
4. (Optional) Click  right to **Arming Schedule** and then set the time when actions will be triggered.
5. (Optional) Click **Copy** to apply the same settings to other cameras.
6. Click **Apply** to save the settings.

Human Body Detection

Human body detection alarms occur when the presence of human being is detected in the specified area.

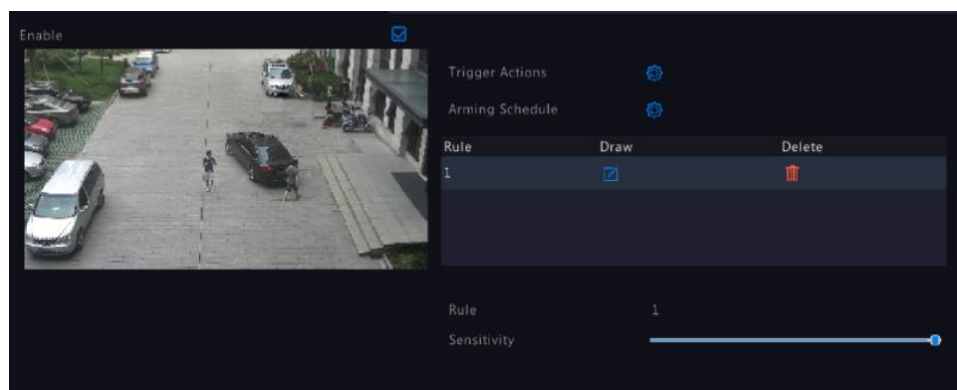
1. Click **Alarm > Human Body Detection**.





2. Enable human body detection by selecting the check box.
3. Click , and then draw the detection area.

NOTE: Only one detection area is allowed for each camera.

4. Set detection sensitivity. The higher the sensitivity, the more likely a human body will be detected.
5. Click  right to Trigger Actions

Video Loss

A video loss alarm occurs when the NVR loses video signals from a camera. Video loss alarm is enabled by default.

1. Click **Alarm > Video Loss**. To disable video loss alarm for a channel, click , which then changes to .
2. Click  under **Trigger Actions** and set action(s) to trigger. For more details, see [Alarm-Triggered Actions](#).

NOTE: Video loss alarm cannot trigger recording, preset, preview (live view) and snapshot actions for the current camera.

3. Click  under **Arming Schedule** and then set the time when actions will be triggered.
4. (Optional) Click **Copy** to apply the same settings to other cameras.

Alert

The NVR reports an alert when an event occurs in the system. The following are some alerts and their definitions in the system.

- **Hard Disk Space Low:** Less than 10% of disk space remains.
- **Hard Disk Full:** No disk space.
- **Disk Offline:** A disk is not properly connected or is damaged.
- **Disk Abnormal:** A disk can be detected but cannot be accessed.
- **Illegal Access:** A failed login attempt for a username that does not exist or a password that is incorrect.
- **Network Disconnected:** Network connection is lost.
- **IP Conflict:** Devices on the network use the same IP address.
- **Recording/Snapshot Abnormal:** Storage resource cannot be found, for example, when all hard disks are removed, or when there is no disk in disk group.

Perform the following steps to configure an alert:

1. Click **Alarm > Alert**.
2. Select an alert type, select the desired actions, and then select the camera(s) for which you want to enable alarm output.

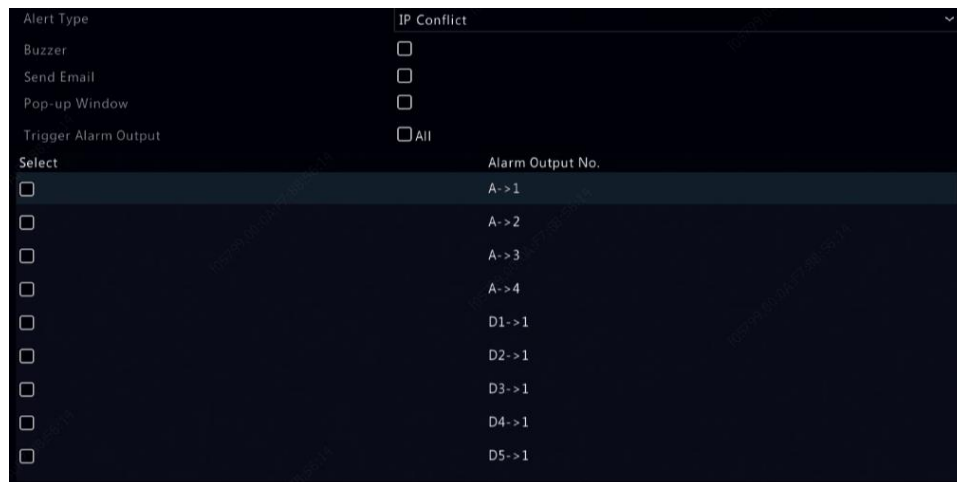



3. Click **Apply** to save the settings.

Audio Detection

An audio detection alarm occurs when a camera detects a sudden change in sound volume.

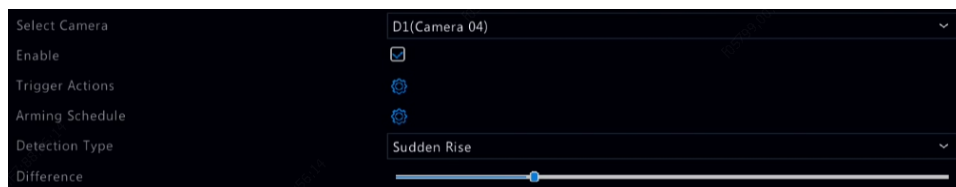
1. Click **Alarm > Audio Detection**.
2. Select the camera and then select **Enable** to enable audio detection.



3. Click  right to **Trigger Actions** and set action(s) to trigger. For more details, see [Alarm-Triggered Actions](#).
4. (Optional) Click  right to **Arming Schedule** and then set the time when actions will be triggered.
5. Select a detection type and adjust the settings as needed.

Detection Type	Description
Sudden Rise	An alarm occurs when the rise of volume exceeds the set value.
Sudden Fall	An alarm occurs when the fall of volume exceeds the set value.
Sudden Change	An alarm occurs when the rise or fall of volume exceeds the set value.
Threshold	An alarm occurs when the volume exceeds the set value.

6. Click **Apply** to save the settings.

Buzzer

The buzzer can be triggered by alarms to alert the user. Follow the steps to set how long the buzzer will buzz after it is triggered.

1. Click **Alarm > Buzzer**.

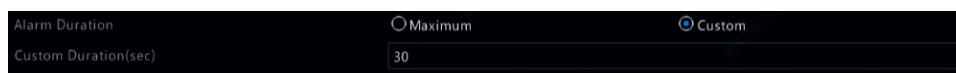

2. Set the duration as needed. The range is from 1 to 600 seconds.
3. Click **Apply** to save the settings.

Doorbell Call

Doorbell calling alarms are enabled by default on the NVR when a doorbell is connected. To disable doorbell calling alarm or change alarm settings, click **Alarm > Doorbell Call**.

Camera	Status	Trigger Actions	Arming Schedule
D1	Enabled		
D2	Enabled		
D3	Enabled		
D4	Enabled		
D5	Enabled		
D6	Enabled		

Alarm-Triggered Actions

An alarm can trigger actions, for example, buzzer, recording, and preview. The supported actions may vary with NVR model.

- **Alarm-Triggered Buzzer:** The NVR makes a buzzing sound when an alarm occurs.
- **Alarm-Triggered E-mail:** The NVR e-mails an alarm message to a specified email address when an alarm occurs.
- **Alarm-Triggered Pop-up Window:** A window pops up when an alarm occurs.
- **Alarm-Triggered Recording:** The NVR records video from a specified camera when an alarm occurs.
- **Alarm-Triggered Snapshot:** The NVR takes a snapshot when an alarm occurs.
- **Alarm-Triggered Preset:** A PTZ camera rotates to a preset position when an alarm occurs.
- **Alarm-Triggered Preview:** The NVR plays live video in full screen when an alarm occurs.
- **Alarm-Triggered Alarm Output:** The NVR outputs an alarm to trigger actions by a third-party device when an alarm occurs.

Manual Alarm

Manual Alarm Output

Follow the steps to trigger or clear an alarm output manually.

1. Click **Manual > Alarm > Manual Alarm**.
2. To trigger an alarm output manually, select the desired channel and then click **Trigger**. To clear an alarm output manually, select the desired channel and then click **Clear**.

Manual Buzzer

Follow the steps to stop the buzzer manually.

1. Click **Manual > Alarm > Buzzer**.
2. Select the buzzer (in Started status) and then click **Stop**.

VCA

VCA means VCA data including behavior, human face, and people counting. Only certain NVR models support this function, and available features may also vary depending on NVR models. You need to select **Save VCA Images** under **Alarm > VCA** before using behavior search and face search functions.

VCA Configuration

VCA refers to Video Content Analysis. VCA functions include face recognition, perimeter protection, and exception detection.

1. Click **Menu > VCA > VCA Config**.
2. Choose Camera Side Analysis or NVR Side Analysis.
 - Camera Side Analysis: The analysis is performed by the camera.
 - NVR Side Analysis: The analysis is performed by the NVR

NOTE:

- The checkbox of a function that is grayed out means that the function is not supported by the camera or the NVR.
- NVR Side Analysis depends on the device capability. Click **VCA Config > Intelligence Usage** to view details.

3. Click  to enter the configuration page of that function.



Face Detection

Face detection is used to detect human faces in a specified surveillance area.



1. Select the detection area. You may choose full screen or specify an area to detect. If you select **Specify Area**, click **Draw Area** and then draw a detection area using the mouse.
2. Set face detection sensitivity. The higher the sensitivity, the more likely a face will be detected.

NOTE: The lower the sensitivity, the less likely a side face or blurring face will be detected. Adjust the detection sensitivity as needed to achieve optimal effects.

3. Click **Draw** and then draw a detection area using the mouse. Adjust detection sensitivity as needed to achieve optimal effects.
4. Configure trigger actions. Click  right to **Trigger Actions** and set action(s) to trigger. For more details, see [Alarm-Triggered Actions](#).
5. Configure an arming schedule. Click  right to **Arming Schedule** and then set the time when actions will be triggered.
6. (Optional) Click  right to **Advanced**, and complete the settings.



Advanced	
Min. Pupillary Distance(px)	0
Number of Snapshots	0
Enable Face Selection	<input type="checkbox"/>
Face Selection Mode	Effect Priority
Number of Selected Photos	0

(Note: The minimum pupillary range: 20px-150px)

OK Cancel

- **Min. Pupillary Distance:** the minimum resolution between two pupils. The face with pupillary distance smaller than the value will not be captured.
- **Number of Snapshots:** the total number of snapshots to take for a face during the detection. Up to 30 snapshots are allowed.
- **Face Selection:** Enable face selection, choose selection mode, then complete the settings.
 - **Effect Priority:** During the face' stay in the surveillance area, select and upload the face snapshots with best image quality. You can set the number of snapshots.
 - **Speed Priority:** Upload the best face snapshots within the time period from when the face enters the surveillance area to when the set time is up.
 - **Periodic Priority:** From the time when the face enters the surveillance area, select and upload one snapshot in every set time period.

Face Recognition

Only certain device models support face recognition. To use this function, you need to enable face detection first, and complete the settings in List Management and Face Comparison.

1. Enable **Face Detection**. Refer to [Face Detection](#) for detailed steps.
2. Add face list.
 - a. Click **Menu > VCA > List Management > Face List**.



- b. Click  to add a new face list. You may also use the default list.

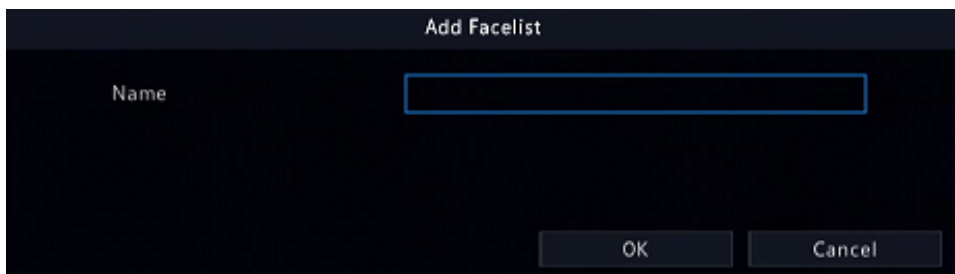

3. Import face pictures. You may choose to add a single piece of face data or import a file containing face data.
 - a. Import a file containing face data
 - i. Click **Export Template** to export the CSV template to a storage device.

NOTE: A USB storage device is required to export the template on the local interface. Export the template on the Web interface (**Smart > List Management**) if you do not have a USB storage device.
 - ii. Complete your face data file by referring to the Face Template Import Guide.
 - iii. Select the target face list, click **Import**, and select the csv file you have edited.

- b. Add a single piece of face data

Click **Add**, then select the face image and enter the required information in **Add Face Info** window.



- 4. Configure monitoring task for face recognition.
 - a. Click **Add Monitoring Task**, and complete the settings of monitoring schedule and triggering actions based on your needs.

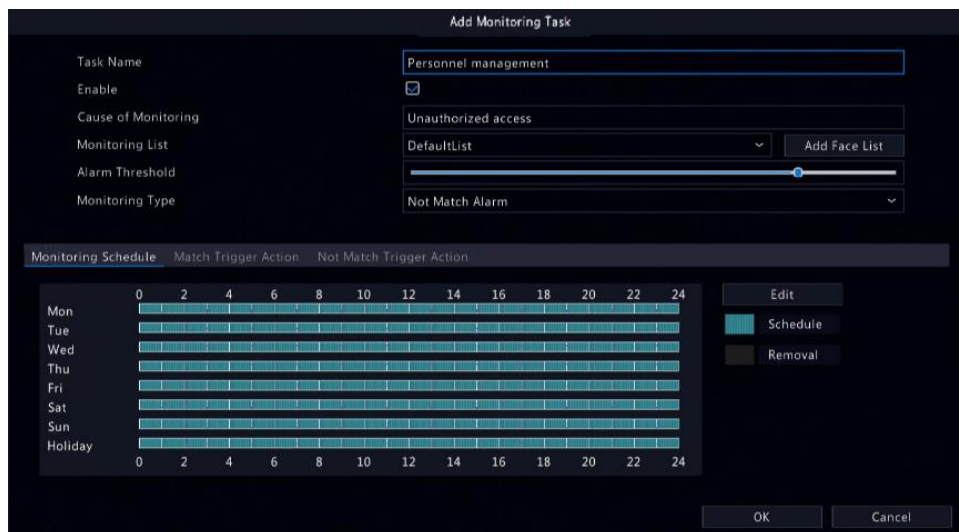

Configure Monitoring Task and Schedule

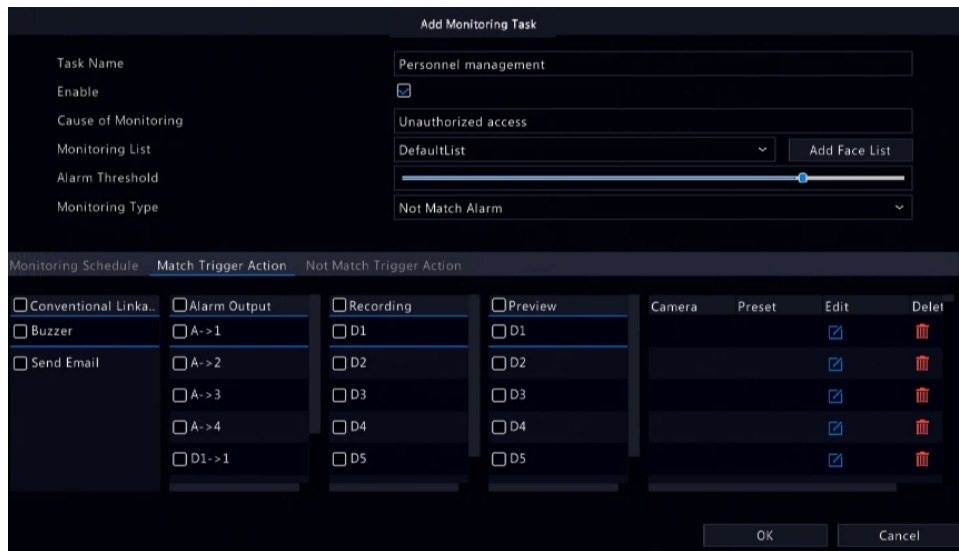

Configure Trigger Action

b. Click **OK** to finish.



NOTE: See [Alarm-Triggered Actions](#) for details.

5. View face comparison results.

- In preview window, click  on the screen toolbar.
- Click **Preview Mode > Smart**, then face recognition results are displayed on the right side.

NOTE:



- In Smart mode, click  in the upper right corner to configure the information to display.
- Click **Preview Mode > Normal** to exit Smart Mode.

Intrusion Detection

Intrusion detection is used to detect objects entering specified area(s) and trigger actions as needed.

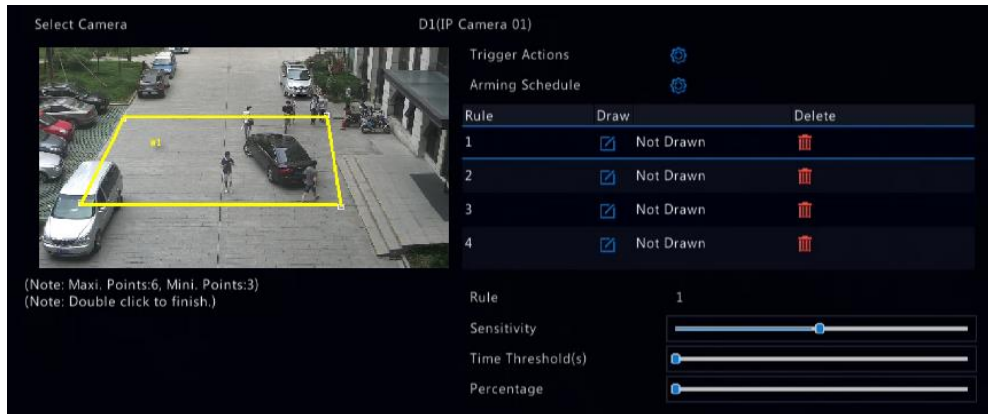
1. Click **Menu > VCA > Intrusion Detection**.





2. Select the camera and then select **Enable** to enable intrusion detection.
3. Draw detection areas on the screen and set detection rules including sensitivity, threshold and percentage. Up to four areas are allowed. The threshold means the minimum length of time an object stays in the detection area(s). The percentage means the proportion of target object size to the size of the detection area. An alarm occurs when the threshold or the percentage is exceeded.
4. Click  on **Trigger Actions** and set action(s) to trigger. For more details, see [Alarm-Triggered Actions](#).
5. (Optional) Click  to **Arming Schedule** and then set the time when actions will be triggered.
6. Click **Apply** to save the settings.

Cross Line Detection

Cross line detection is used to detect whether any object crosses a virtual line on the screen and trigger alarms as needed.

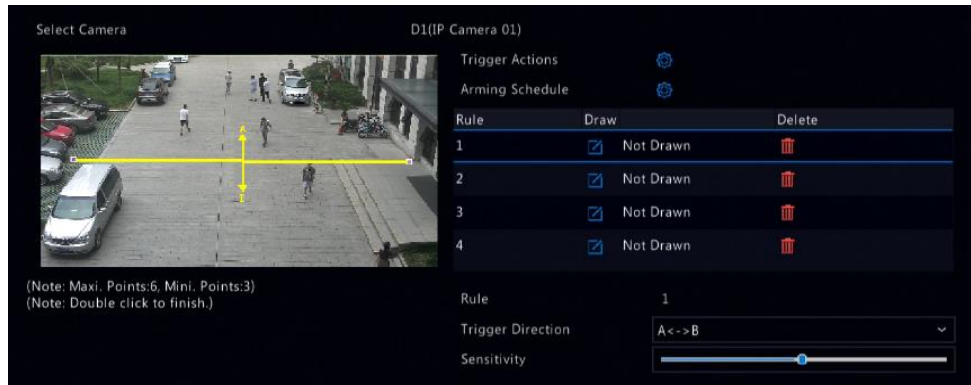
1. Click **Menu > VCA > VCA Config > Cross Line Detection**.



2. Select the camera and then select **Enable** to enable cross line detection.
3. Draw detection line(s). Up to four are allowed. Set detection rules, including entrance direction, sensitivity.
4. Click  on **Trigger Actions** and set action(s) to trigger. For more details, see [Alarm-Triggered Actions](#).
5. (Optional) Click  on **Arming Schedule** and then set the time when actions will be triggered.
6. Click **Apply** to save the settings.

Enter Area Detection

Enter area detection detects objects entering a user-specified area. The NVR takes snapshots and reports an alarm when the detection rule is triggered.

1. Go to **Menu > VCA > VCA Config**.
2. Select a camera.
3. Select **Enter Area** and click  to configure it.

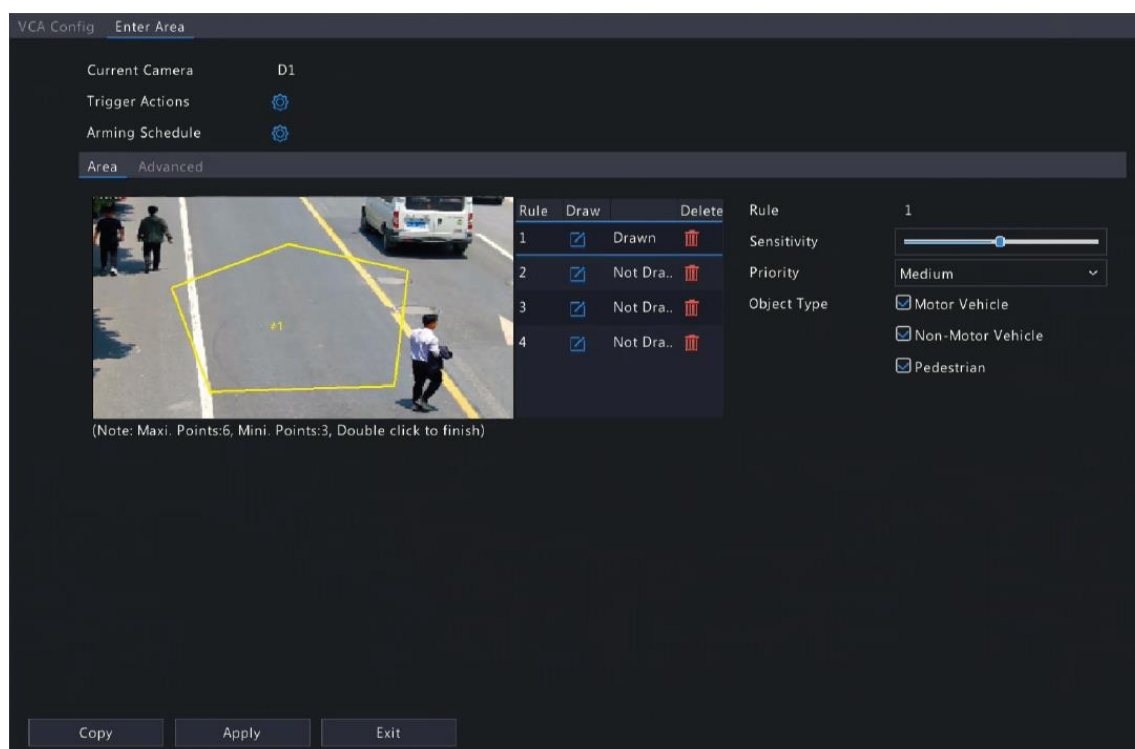

4. Set the **deteccion** rules. The four detection rules should be set separately.

Parameter	Description
Detection Area	Select Rule 1, click the Edit icon, and then draw a detection area in the left preview window. Click on the image and drag to draw a line. Repeat the action to draw more lines to form an enclosed shape as needed. Up to 6 lines are allowed. NOTE: For a rule in Drawn state, you can click the Edit icon to redraw a detection area. To delete a detection area, click the Delete icon.
Sensitivity	Set the sensitivity by dragging the slider. The higher the sensitivity, the more likely leaving behaviors will be detected, but the false alarm rate will increase.
Priority	Select the priority of the detection rule, including High , Medium , and Low . The NVR detects the rule that is triggered first by default. If multiple rules are triggered at the same time, the NVR detects the rule with higher priority.
Object Type	Select the object(s) to be detected, including Motor Vehicle , Non-Motor Vehicle , and Pedestrian .

5. Under the **Advanced** tab, you can filter objects by size. For example, if you have selected Motor Vehicle as a detection object, after you set the Max. Size and Min. Size for it, motor vehicles larger than the max. size and smaller than the min. size will not be detected.
 - a. Select an object type and click the Edit icon. A **Max. Size** box and a **Min. size** box appear in the left preview window.
 - b. Modify the max./min. size by adjusting the size of the box by dragging the handle of the box.

NOTE:

- The Max. Size and Min. Size settings take effect after you select the object as a detection object.
 - The width and height of the maximum size must be greater than that of the minimum size.
6. Set the alarm-triggered action and arming schedule. For more details, see [Alarm-Triggered Actions](#).
 7. Click **Apply** to save the settings.

People Counting

People counting is used to count the number of people entering or leaving an area. Only certain NVR models support this function. This function cannot be used at the same time with other VCA functions.



1. Select the **Enable Shoulder Demarcation**. Draw a virtual line on the screen to set the minimum width of detection. People narrower than the set width will be ignored.
2. Click the **Draw** button and then draw rules on the left. Set entrance direction and sensitivity, as needed.
3. By selecting **Enable Clear by Schedule**, you can have people counting OSD reset at a specified time every day. You may also click **Clear Counting Result** to clear the OSD



immediately. Resetting people counting OSD only changes the OSD. It does not change report statistics.

4. Click **Apply** to save the settings.

Defocus Detection

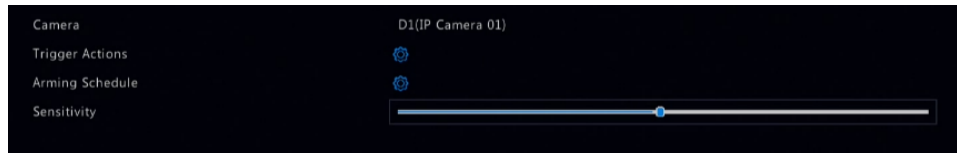
Use defocus detection to check whether the camera focuses properly.





1. Click  right to **Trigger Actions** and set action(s) to trigger. For more details, see [Alarm-Triggered Actions](#).
2. (Optional) Click  right to **Arming Schedule** and then set the time when actions will be triggered.
3. Set detection sensitivity and then click **Apply** to save the settings.

Scene Change Detection

Use defocus detection to detect the change of surveillance environment caused by external factors such as intentional rotation of the camera.





1. Click  right to **Trigger Actions** and set action(s) to trigger. For more details, see [Alarm-Triggered Actions](#).
2. (Optional) Click  right to **Arming Schedule** and then set the time when actions will be triggered.
3. Set detection sensitivity and then click **Apply** to save the settings.

Auto Tracking

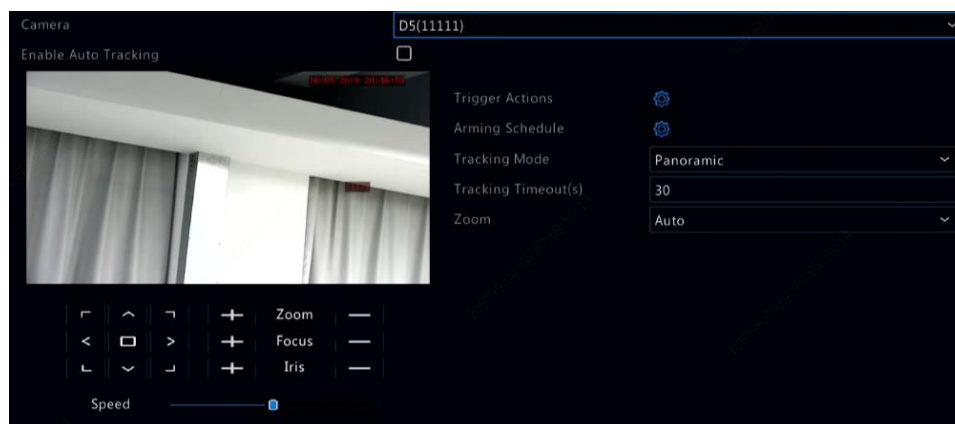
Auto tracking detects moving objects in the scene and automatically tracks the first object detected.



1. Click  right to **Trigger Actions** and set action(s) to trigger. For more details, see [Alarm-Triggered Actions](#).
2. (Optional) Click  right to **Arming Schedule** and then set the time when actions will be triggered.
3. Set the tracking mode (currently only Panoramic) Set tracking timeout and zoom ratio.

NOTE:



- Tracking timeout means the maximum length of time the camera tracks an object automatically. The range is 1-300 seconds and the default is 30 seconds. When the tracking timeout is over, the camera stops tracking and restores the original scene and status.
 - Zoom means zoom ratio and includes **Auto** (default) and **Current Zoom**. Auto means the camera automatically adjusts the zoom ratio according to the tracking distance and thus captures more details on the tracking object; **Current Zoom** means the camera maintains the original zoom ratio during tracking and thus attends to the whole scene.
4. Click **Apply** to save the settings.

Object Left Behind

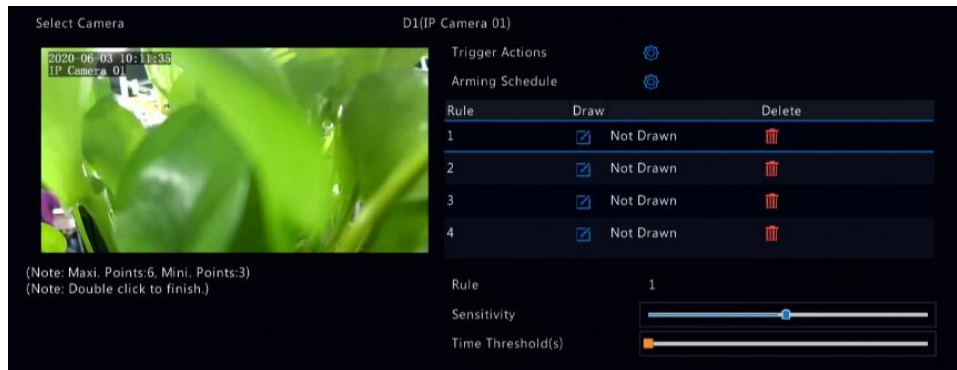
Detect object left behind in specified areas and trigger an alarm.







1. Click  to draw the detection area.

NOTE: When drawing a detection area, you can use up to 6 points to specify the area. Up to 4 detection areas are allowed.
2. Set the sensitivity and time threshold:
 - **Sensitivity:** The higher the sensitivity, the more likely an object left behind will be detected.
 - **Time Threshold:** An alarm will be triggered when the length of time an object is left behind in a detection area exceeds this value.
3. Click  right to **Trigger Actions** and then set the action(s) to trigger. For more details, see [Alarm-Triggered Actions](#).
4. (Optional) Click  right to **Arming Schedule** and then set the time when actions will be triggered.
5. Click **Apply** to save the settings.

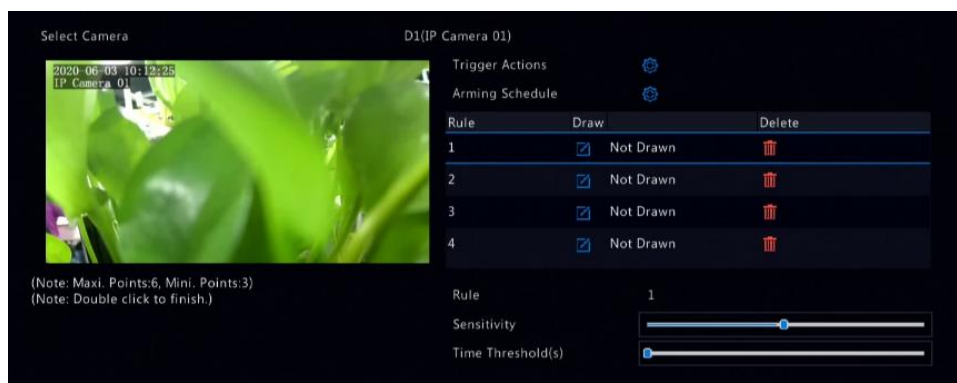
Object Removed

Detect object removed from specified areas and trigger an alarm.



1. Click  to draw detection areas.
NOTE: When drawing a detection area, you can use up to 6 points to specify the area. Up to 4 detection areas are allowed.
2. Set the sensitivity and time threshold:
 - **Sensitivity:** The higher the sensitivity, the more likely an object removed will be detected.
 - **Time Threshold:** An alarm will be triggered when the length of time an object is removed in a detection area exceeds this value.
3. Click  right to **Trigger Actions** and then set the action(s) to trigger. For more details, see [Alarm-Triggered Actions](#).
4. (Optional) Click  right to **Arming Schedule** and then set the time when actions will be triggered.
5. Click **Apply** to save the settings.

VCA Search

VCA searches for data of each VCA function. Only certain NVR models support this function. The search result, application scenario and settings vary with the VCA function.

Face Snapshot Search

Use face snapshot search to search for captured face images.

1. Click **VCA > VCA Search > Face Snapshot**.
2. Select cameras, set a search period, and then click **Search**. Search results are displayed.
3. View search results in a chart or table. Back up search results (including images and recordings) as needed. To view videos recorded when the face was detected (around 10 seconds before and after), click the play button. The following shows an example.

Behavior Search

Use behavior search to search for line crossing, intrusion, enter area and leave area detection results.

1. Click **VCA > VCA Search > Behavior Search**.
2. Set search conditions and then click **Search**. Search results are displayed.

People Counting

Count people entering and/or leaving an area during a specified period (day, week or year).

1. Click **VCA > VCA Search > Counting**.
2. Select the camera, counting type (people entered or left), report type (daily, weekly, monthly or yearly), set a time period, and then click **Count**. Search results are displayed. You may choose to display search results using a chart or table.
3. (Optional) To save the counting statistics to a connected USB storage device, click **Backup**.

Network Configuration

Network configuration is required if your NVR operates in a network.

NOTE: The default IP address is 192.168.1.30 for NIC 1 and 192.168.2.30 for NIC 2, and likewise.

Basic Configuration

TCP/IP

1. Click **Network > Basic**.
2. Set the network parameters as needed. For some NVR models, DHCP is enabled by default.

You can choose a working mode if your NVR has two NICs:

- **Multi-address mode:** The two NICs work independently and can be configured separately. Either NIC can be chosen as the default route, and data will be forwarded through this NIC when the NVR connects to the extranet.
- **Load balance mode:** The two NICs are bound to the same IP address and work together to share network traffic.
- **Net fault-tolerance mode:** The two NICs are bound to the same IP address. In cases where one NIC fails, the other takes over service seamlessly from the faulty one to ensure network connectivity.

Working Mode	Multi-address
Select NIC	NIC1
<input type="checkbox"/> Enable DHCP	
IPv4 Address	206 . 3 . 0 . 86
IPv4 Subnet Mask	255 . 255 . 255 . 0
IPv4 Default Gateway	206 . 3 . 0 . 1
IPv6 Mode	Router Advertisement
IPv6 Address	fe80::4aea:63ff:fe6a:c792
IPv6 Prefix Length	64
IPv6 Default Gateway	::
MAC Address	48:ea:63:6a:c7:92
MTU(Bytes)	1500
Preferred DNS Server	114 . 114 . 114 . 114
Alternate DNS Server	8 . 8 . 8 . 8
Default Route	NIC1

3. Click **Apply** to save the settings.

NOTE:

- For an NVR with multiple NICs, you can configure the NICs and choose a default route (currently NIC1).
- If your NVR has a PoE port or a switching port, you can configure an internal NIC IPv4 address.

**CAUTION:**

- If you switch the working mode, the enabled 802.1x and ARP protection will be disabled automatically.
- The valid MTU ranges from 576 to 1500 (1280-1500 for IPv6). To use IPv6, make sure the NVR and PC can connect to each other using IPv6 addresses. To view live or recorded videos, make sure the IPv4 addresses are also connectable.

DDNS

If your NVR is connected to the Internet through PPPoE, the IP address of the network changes every time it connects to the ISP server without your awareness. This is inconvenient when you remotely access your NVR with an IP address. To avoid this issue, you can register with an DDNS server to obtain a domain name for your NVR and then access your NVR by visiting the domain name instead of an IP address (<http://DDNS server address/NVR's domain name>) using a web browser.

1. Click **Network > Basic > DDNS**.
2. Enable DDNS, select a DDNS type, and then complete other settings.
 - If the DDNS type is **DynDNS** or **No-IP**, enter the domain name, username and password. The domain name is the one that you have successfully registered at a domain name registration website (e.g., DynDNS). The username and password are those of the account you have registered at the domain name registration website (e.g., DynDNS).
 - If the DDNS type is **MyDDNS**, enter a valid domain name for your NVR and then click **Test** to see if the domain name is available.
3. Click **Apply** to save the settings.

Email

When Email is enabled as a triggered action (in Trigger Actions windows) and configured properly, the NVR sends an email notification to specified email address(es) when an alarm occurs during the arming schedule. The email contains basic alarm information such as alarm type, alarm time, camera ID, and camera name, etc.

Before using this function, make sure the NVR has a functional connection to an SMTP server with which you have a valid email account. Depending on the intended recipients, a connection to the Internet may be required.

Only certain NVR models support this function.

1. Click **Network > Basic > Email**.
2. Configure the related parameters. If server authentication is required, you need to enter the correct username and password. Click **Test** to send a test email. Enter a valid SMTP server address and port number, and then select **Enable TLS/SSL** if required.

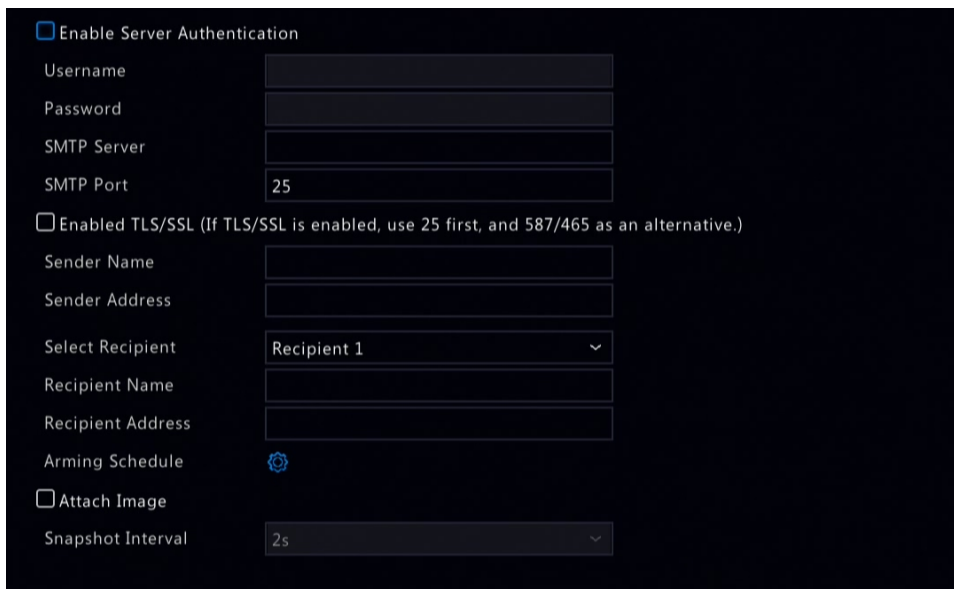

The screenshot shows the Email configuration window with the following fields and options:

- Enable Server Authentication
- Username: [Text Input]
- Password: [Text Input]
- SMTP Server: [Text Input]
- SMTP Port: 25
- Enabled TLS/SSL (If TLS/SSL is enabled, use 25 first, and 587/465 as an alternative.)
- Sender Name: [Text Input]
- Sender Address: [Text Input]
- Select Recipient: Recipient 1 (Dropdown)
- Recipient Name: [Text Input]
- Recipient Address: [Text Input]
- Arming Schedule: [Gear Icon]
- Attach Image
- Snapshot Interval: 2s (Dropdown)

NOTE:

- Enter a valid SMTP server address and port number, and then select **Enable TLS** if required.
- Select **Attach Image** if you want snapshots to be sent via email. Make sure Email and snapshot have been enabled in the **Trigger Actions** window.
- Only certain NVR models support image attachment. You may click **Test** to check whether the email can be sent successfully.

3. Click **Apply** to save the settings.

Platform Configuration

SNMP

Use SNMP to connect to a platform and obtain system time.

1. Click **Network > Platform**. Select **Enable SNMP**.



2. Select an **SNMP Type**.
 - **SNMP V2**: Set Read Community Name and Write Community Name, which are used by the platform to read data on NVR.
 - **SNMP V3**: Set authentication password (for the platform to access the NVR) and encryption password (for encrypting data sent from the NVR to the platform).
3. Click **Apply**.

Alarm Service

Use this function to send alarm signals to an external alarm device (for example, alarm control panel) when an alarm or an alert occurs on the NVR.

1. Click **Network > Platform > Alarm Service**.

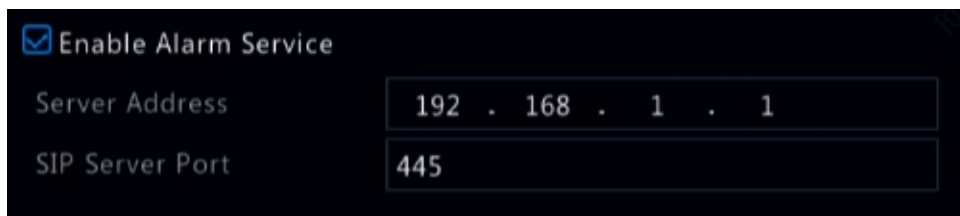

2. Select **Enable Alarm Service**, and set the server address and SIP server port.

NOTE: The NVR only sends alarm signals when an alarm or alert occurs; users need to implement alarm receiving and reporting for the external alarm device separately.

Video & Image Database Local Config

1. Click **Network > Platform > Configure VIID Service**.

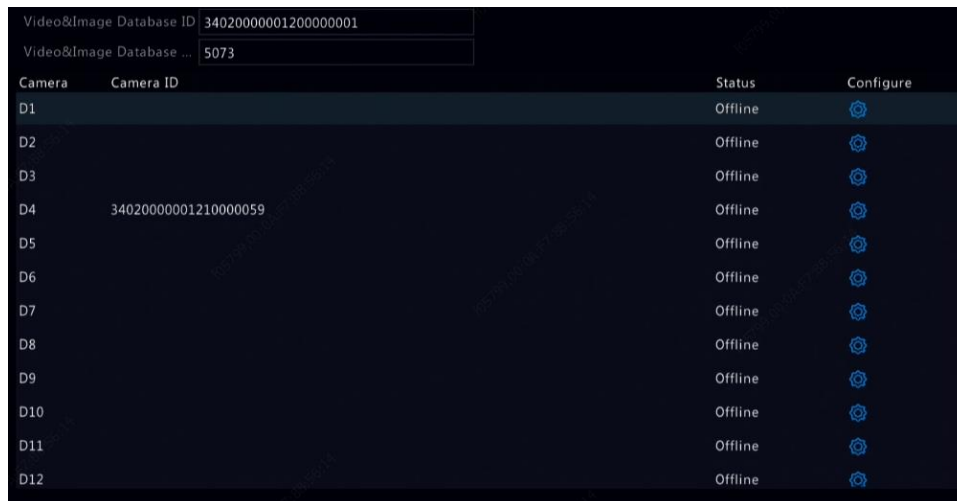

Camera	Camera ID	Status	Configure
D1		Offline	
D2		Offline	
D3		Offline	
D4	340200000121000059	Offline	
D5		Offline	
D6		Offline	
D7		Offline	
D8		Offline	
D9		Offline	
D10		Offline	
D11		Offline	
D12		Offline	

2. Use the default database ID and port, click  to set the camera ID.

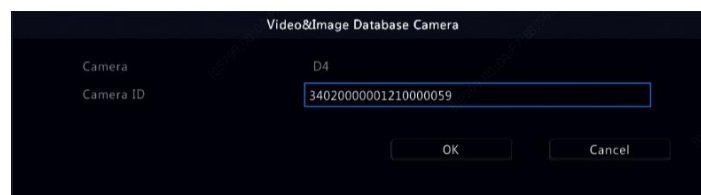

Video&Image Database Camera

Camera: D4

Camera ID:

OK Cancel

3. Click **OK**.
4. Log in to the camera's Web interface and complete the settings on Setup > Config Management > Photo Server. The settings may vary depending on the platform communication type you choose. Some settings are described below:
 - TMS Server: IP address of the NVR
 - TMS Server Port: Database port configured on the NVR
 - Platform Communication Type: Choose the correct type
 - LPRD ID: Database ID configured on the NVR
 - Device ID: Camera ID configured on the NVR
 - Platform Access Code: Use the default setting
5. Click **Save**. Check the management server status on the lower left corner of the page. A green icon means the camera is connected to the Video & Image database. Now configuration on the camera is complete.

Vehicle Control

Vehicle control allows you to view license plate recognition results. To use this function, you need to configure the plate lists, and set vehicle monitoring task in Video & Image database (see [Video & Image Database Server](#)).

Add Plate List

1. Click **Menu > VCA > Vehicle Control > Plate List**.



2. Click **+Add** to add a plate list.
3. Add plate number(s) to plate list.
 - To add a single plate, click **Add**, and then enter the plate number in the window displayed.

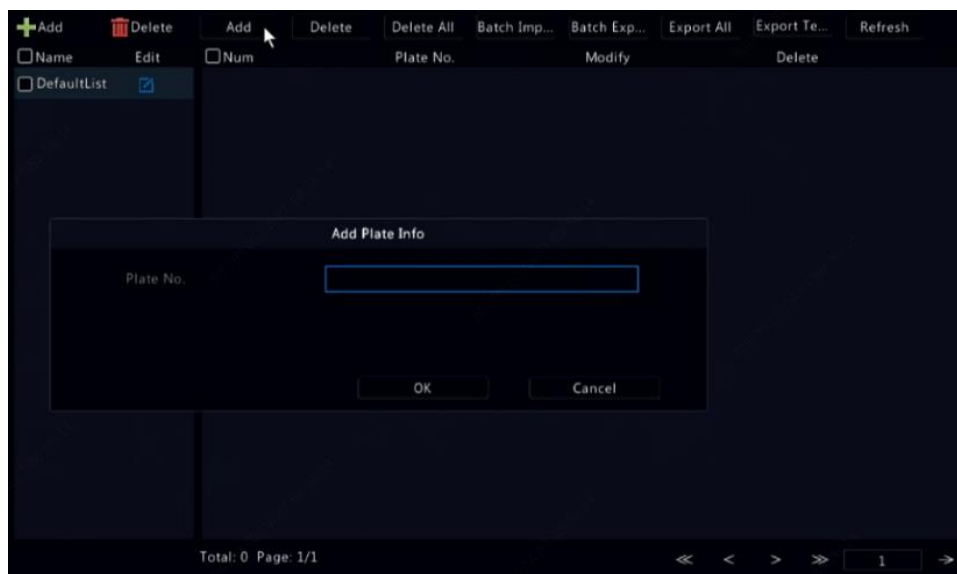

- To batch add plates, click **Export Template** to export template to a USB storage device first. Then edit the list and click **Batch Import** to import the edited file.

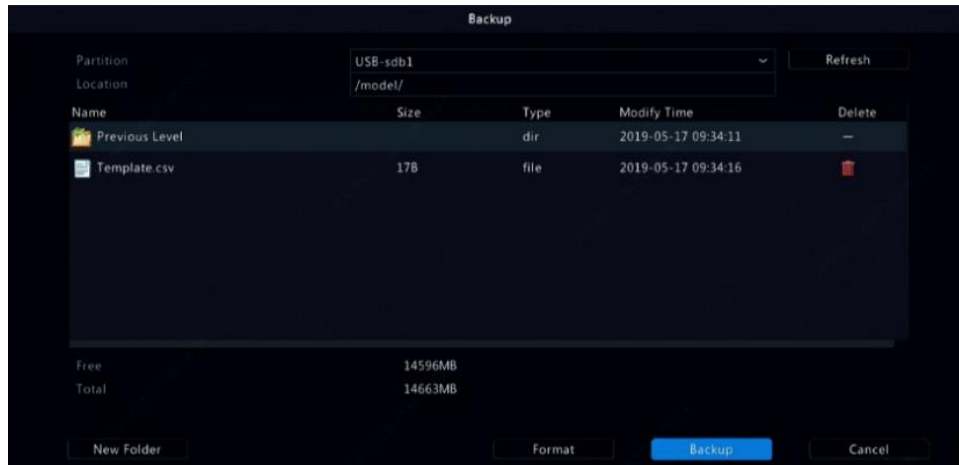

After importing is completed, click **Cancel** to return to **Plate List**.

NOTE: The import failures and causes are displayed in **Import Status** window. No result in the window means all plate numbers are exported successfully.

Add Vehicle Monitoring Task

1. Click **Menu > VCA > Vehicle Control > Vehicle Alarm Control**.
2. Click **Add** to add a monitoring task.



3. View license plate recognition results.
 - In the preview window, click  on the screen toolbar.
 - Right-click and select **Preview Mode > Smart**.

NOTE:

- In smart mode, click  in the upper-right corner to set the display content.
- To exit smart mode, right-click and select **Preview Mode > Normal**.

Video & Image Database Server

Video & Image database server is used to connect to an upper platform for unified management of face and plate data.

1. Click **Menu > Network > Platform > Video&Image Database Server**.



2. Select **Enable Video&Image Database Server**, and complete the settings.

NOTE: The server address, port number, username and password should be consistent with those configured on the platform.

Advanced Configuration

PPPoE

The NVR allows access through Point-to-Point over Ethernet (PPPoE).

1. Click **Network > Advanced > PPPoE**.
2. Enable PPPoE by selecting the check box.
3. Enter the username and password provided by your Internet Service Provider (ISP).
Network information including IP address appears when dial-up succeeds.

NOTE: If your NVR has multiple NICs, PPPoE dial-up will be implemented through the NIC specified as the default route.

4. Click **Apply** to save the settings.

Port

Normally the default port numbers need no modification. This function is mainly used together with the port mapping function. See [Adding an IP Device](#) for more details.

1. Click **Network > Advanced > Port**.
2. Configure ports as planned. Each port number must be unique.

HTTP Port	80
RTSP Port	554
HTTPS Port	443
RTSP URL Format	<pre>rtsp://<ip>:<port>/unicast/c<channel number>/s<stream type>/live <channel number>: 1-n <stream type>: 0(main stream) or 1(sub stream)</pre>

NOTE:

- A valid port number ranges from 1 to 65535, among which 21, 23, 2000, 3702 and 60000 are reserved.
- An RTSP URL can be used to view live video of a channel of the current NVR from another NVR. See Option 5 in [Adding an IP Device](#) for more information.

3. Click **Apply** to save the settings.

Port Mapping

Two port mapping methods are available:

- (1) Universal Plug and Play (UPnP)
- (2) Internal and external mapping

UPnP

UPnP enables the NVR to discover other devices on the network and establish network services such as data sharing and communication.

To use UPnP in your NVR, you must enable UPnP in the connected router. With UPnP enabled for Network Address Translation (NAT), the ports on the NVR can be mapped automatically to the router, and computers can access your NVR from outside the LAN.

1. Click **Network > Advanced > Port Mapping**.
2. UPnP is enabled by default. Select the desired mapping type from the drop-down list. To map ports manually, select **Manual** and then set external ports for the router.

NOTE:

- Automatic mapping (Auto) is recommended. Ports will conflict if not configured properly.
- For an NVR with multiple NICs, port mapping should be configured based on the NIC specified as the default route.

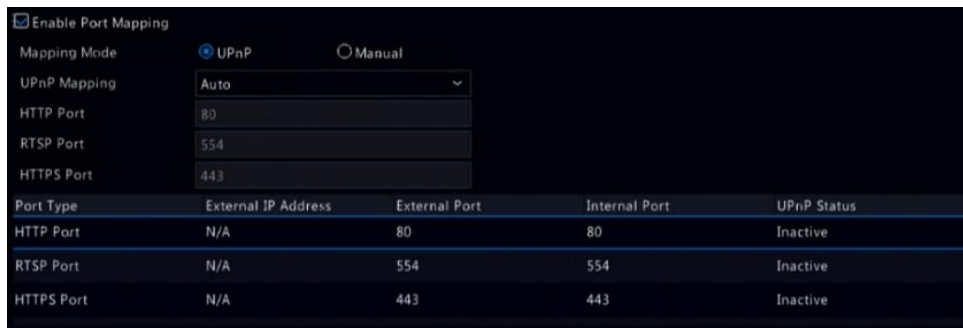

3. Click **Refresh** and check that **Active** is displayed for these ports under **UPnP Status**.
4. Click **Apply** to save the settings.

Manual Port Mapping

If your router does not support UPnP, then you need to configure internal and external ports manually.

NOTE:

- The principle of port mapping is that the internal and external ports of the NVR are consistent with that of the router.
- Some routers may require the same internal and external ports for the NVR and the router.

1. Click **Network > Advanced > Port Mapping**.
2. Select **Manual** for **Mapping Mode**, and then set external ports manually.



3. Click **Apply** to save the settings.

NOTE: After port mapping is completed, you may access the Web client of your NVR by entering the following information in the address bar of your web browser: router's WAN port

IP address:external HTTP port. For example, if 10.2.2.10 is the IP address and 82 is the HTTP port, then you enter <http://10.2.2.10:82>.

FTP

Use this function to automatically upload images to a preconfigured FTP server. Only certain NVR models support this function.

1. Click **Network > Advanced > FTP**.
2. Select the check box to enable FTP.
3. Enter the IP address of the FTP server, username and password, remote directory, and upload interval.

NOTE:

- Click **Test** to verify whether an FTP connection can be established.
 - If the remote directory is not specified, the system will create different folders directly by IP, time and camera. You may also specify a remote directly, for example, FTPtest/xxx/xxx, then the system will create the directory first and then create folders by IP, time and camera.
4. Select the desired camera and then click  right to **Upload Schedule**. In the **Upload Schedule** window, select the desired image type and set time periods.

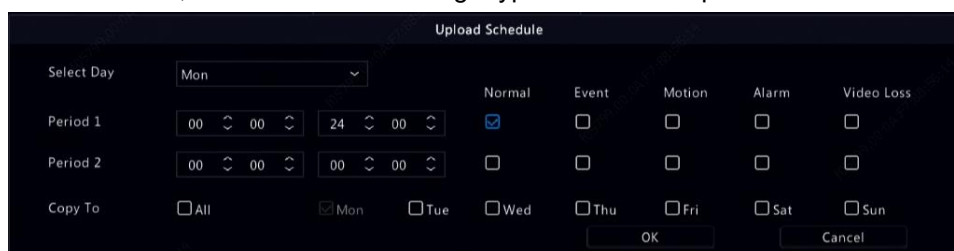

NOTE:

- If you select **Event**, **Motion**, **Alarm** or **Video Loss**, you also need to have configure the corresponding alarm-triggered snapshot. For example, if you select **Motion**, you need to configure alarm-triggered snapshot (select **Motion** in the **Edit Schedule** window).
 - To apply the same settings to other days in a week, select the desired days right to **Copy To**.
5. (Optional) Apply the same settings to other cameras by clicking  right to **Copy** and then selecting desired cameras.
 6. Click **Apply** to save the settings.

NOTE: To apply the same settings to other cameras, click  right to **Copy**, select cameras and then click **OK**.

Multicast

Multicast can be used to realize live view when the number of connecting Web clients exceeds the limit the NVR can accommodate.

1. Click **Network > Advanced > Multicast**.
2. Select the check box to enable multicast, and then enter the multicast IP and port number.

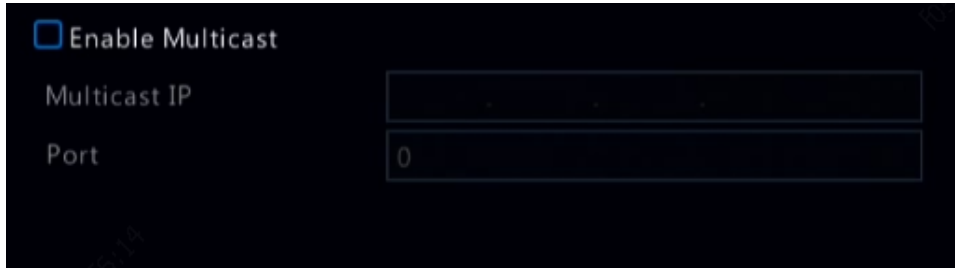

3. Click **Apply** to save the settings.
4. Log in to the Web client and set **Live View Protocol** to **Multicast** under **Setup > Client**.

NOTE: Set the multicast IP correctly. Multicast address is class D address with the range 224.0.0.0 through 239.255.255.255; some are for special use:

- 224.0.1.0--238.255.255.255 can be used on the Internet.
- 224.0.0.0-244.0.0.255: only for use on LAN.
- 224.0.0.1: all-hosts group address, which refers to all the multicast-capable hosts and routers on a physical network.
- 224.0.0.2: for all routers on this subnet.
- 224.0.0.5: for all OSPF routers.
- 224.0.0.13: for all PIMv2 routers.
- 239.0.0.0--239.255.255.255 are for private use like 192.168.x.x.

Disk Configuration

Disk Management

View disk information, including total and free disk space, disk status, disk type, disk usage, and disk property. Admin users can format disks and edit disk property.

1. Click **Storage > Hard Disk**.

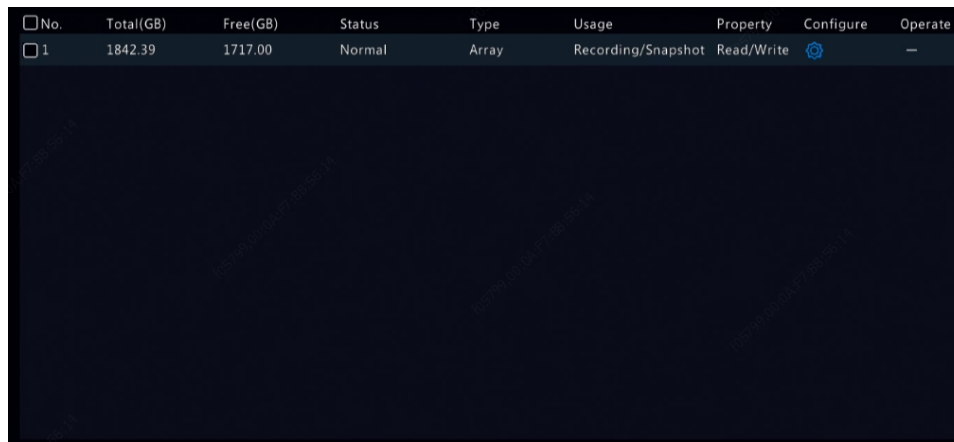

<input type="checkbox"/> No.	Total(GB)	Free(GB)	Status	Type	Usage	Property	Configure	Operate
<input type="checkbox"/> 1	1842.39	1717.00	Normal	Array	Recording/Snapshot	Read/Write		—

2. To add a disk, click **Add**. In the dialog box displayed, select disk usage (recording/snapshot or backup) and disk type (currently NAS only), enter the server address and directory, and then click **Add**. Up to eight NAS disks are allowed.

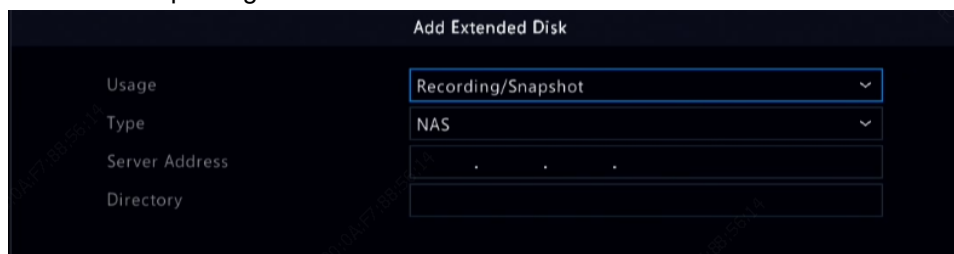

Add Extended Disk

Usage	Recording/Snapshot
Type	NAS
Server Address
Directory

3. To edit disk property, click , and then modify disk usage (recording/snapshot or backup) and disk property (**Read/Write**, **Read Only** or **Redundant**) as needed.

NOTE:

- Disk property can be edited if the disk is used for recording/snapshot.
- The Redundant property is available to certain NVR models.
- You may use external eSATA disks for recording/snapshot or backup purpose and unmount them if necessary

4. To format a disk, select the disk and then click **Format**. A confirmation message appears. Click **Yes**.

NOTE:

- Local disks will be formatted automatically when installed. Extended disks will not.
- Format a disk with caution. All data will be removed.

Space Allocation

Allocate space to store videos and snapshots of a specified camera.

1. Click **Storage > Allocate Space**.



The screenshot shows a configuration window with the following fields and values:

Select Camera	D1(Camera 04)
Used Recording Space(G..	52
Used Image Space(GB)	0
Select Group	Disk Group 1
Disk Capacity	1842 GB free of 1842 GB
Group Capacity	1842 GB free of 1842 GB
Max Recording Space(GB)	0
Max Image Space(GB)	0

2. Select the desired camera and then set the maximum recording space and maximum image space. You can select a disk group only when disk group is enabled under **Storage > Disk Group**. For more information, see [Advanced Configuration](#).
3. Click **Apply** to save the settings.
4. (Optional) Click **Copy** to apply the same settings to other camera(s).

Advanced Configuration

Set whether to overwrite recordings or snapshots when storage is full.

1. Click **Storage > Advanced**.

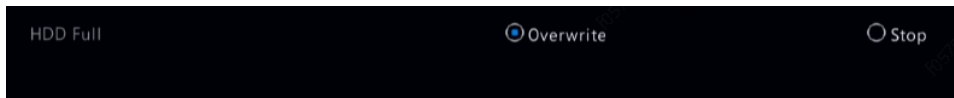

2. Choose an option.

Option	Allocated Space	Description
Overwrite	0	The camera shares unallocated space, and its oldest recordings/snapshots will be overwritten when the space is used up.
	Other values	The camera's oldest recordings/snapshots will be overwritten when its allocated space is used up.
Stop	0	The camera shares unallocated space, and its oldest recordings/snapshots will still be overwritten when the space is used up.
	Other values	The camera's new recordings/snapshots will not be saved when its allocated space is used up.

3. Click **Apply** to save the settings.

System Configuration

Basic Configuration

1. Click **System** > **Basic**.
2. Configure the parameters.

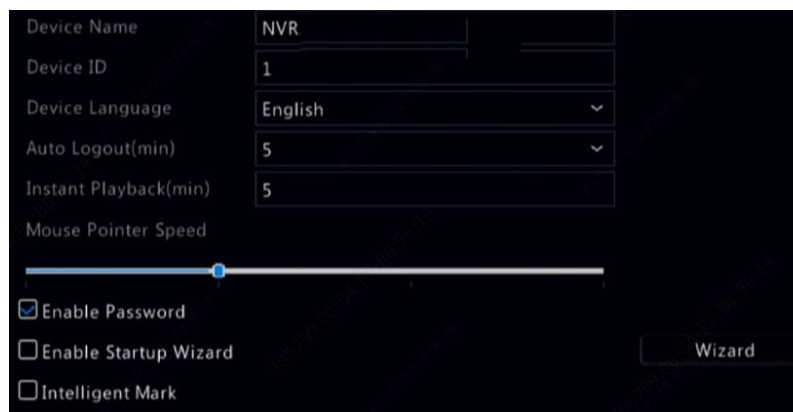

Device Name	NVR
Device ID	1
Device Language	English
Auto Logout(min)	5
Instant Playback(min)	5
Mouse Pointer Speed	<input type="range"/>
<input checked="" type="checkbox"/> Enable Password	
<input type="checkbox"/> Enable Startup Wizard	
<input type="checkbox"/> Intelligent Mark	

3. Click **Apply** to save the settings.

NOTE:

- Only admin can set **Enable Password**.
- If **Enable Password** is not selected, no password is required for local login at system startup. However, a username and password are still required when you log in after a logout.
- You may also set startup Wizard here by clicking **Wizard**.

Time Configuration

Time

1. Click **System** > **Time** > **Time**.
2. Select the correct time zone, and then set date and time formats and the system time. The following shows an example.



Time Zone	(GMT+08:00) Beijing, Hong Kong, Uru
Date Format	YYYY-MM-DD
Time Format	24-hour
System Time	2019-05-17 10:01:53
<input type="checkbox"/> Enable Auto Update	
NTP Server Address	0.0.0.0
NTP Port	123
Update Interval	10m

3. To use Network Time Protocol (NTP), enable NTP, set the address and port number of the NTP server, and the update interval.
4. Click **Apply** to save the settings.

DST

1. Click **System > Time > DST**.
2. Enable DST by selecting the check box, and then set the start time, end time, and DST bias correctly.
3. Click **Apply** to save the settings.

Time Synchronization

Use this function to synchronize camera time with the NVR. Time sync is enabled by default, and cameras will synchronize time with the NVR after getting online, and then synchronize once every 30 minutes.

1. Click **System > Time > Time Sync**.
2. Select **Sync Camera Time** and then click **Apply**.



CAUTION: Use this function with caution if you have more than one NVR on the network.

An IP camera synchronizing time with multiple NVRs at the same time will cause chaotic recordings.

User Configuration

Add, delete users or edit user permissions. Only admin can perform these operations. Device password is required for user configuration.



A user type is a set of permissions in the system. When a user type is assigned to a user, this user has all the permissions specified for the user type.

There are four user types in the system:

- Admin: Default super administrator in the system, has full system access. Its initial password is **123456**.
- Default: Default user reserved in the system, cannot be created or deleted, and only has access to live view and two-way audio. If the default user is denied access, the corresponding channel is locked when no user is logged in, and  appears in the window.
- Operator: Has basic permissions and access to cameras.
- Guest: Only has access to cameras by default.

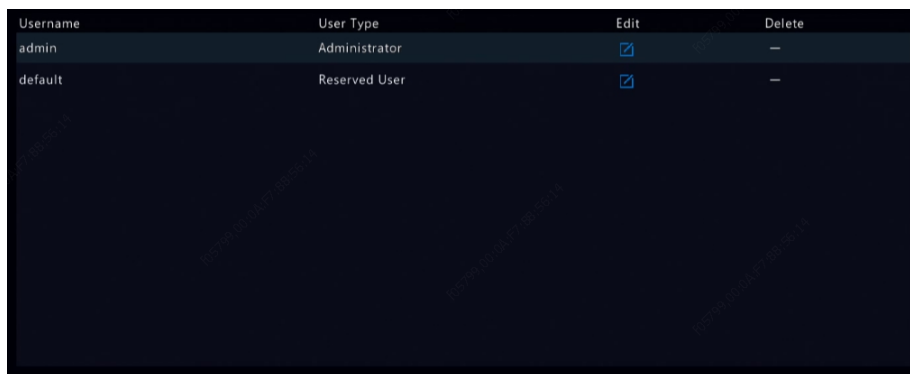
1. Click **System > User**.
2. To add a user, click **Add**, and then set the username, user group, password and permissions as needed. Click **OK** to save the settings.



Username	User Type	Edit	Delete
admin	Administrator		—
default	Reserved User		—

3. To edit or delete a user, click  as needed. If you change the password for a user, the new password takes effect at the user's next login.

Security Configuration

IP Address Filtering

Use this function to enhance security by allowing or forbidding access to the NVR from specified IP addresses.

1. Click **System > Security > IP Address Filtering**.
2. Select **Enable IP Address Filtering**, select **Blacklist** or **Whitelist** from the drop-down list, set the start and end IP addresses, and then click **Add**.

NOTE:

- If **Blacklist** is selected, the NVR denies remote access from the IP address(es) on the list.
- If **Whitelist** is selected, the NVR only allows remote access from the IP address(es) on the list. However, if **Whitelist** is selected with no IP address specified, remote access to the NVR will be denied.



No.	Start IP	End IP	Edit	Delete
-----	----------	--------	------	--------

3. Click **Apply** to save the settings.

ONVIF Authentication

Enable ONVIF authentication under **System > Security > ONVIF Auth** so a username and password will be required for ONVIF-based device access.

Select the check box and then click **Apply**.

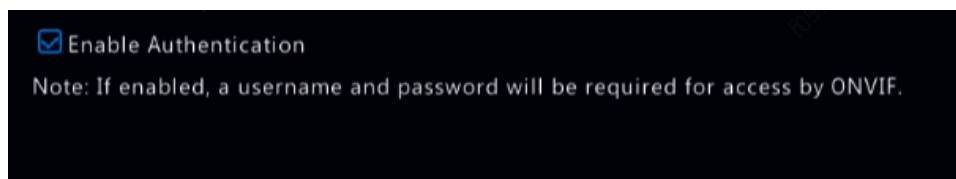

Enable Authentication

Note: If enabled, a username and password will be required for access by ONVIF.

ARP Protection

ARP protocol is used to associate an IP address to a hardware MAC address. ARP attacks mainly occur on LAN, in which attackers use forged IP and MAC addresses. ARP protection prevents this kind of attacks by verifying the gateway's MAC address in all access requests. Note that changing the NIC working mode will disable ARP protection automatically.

1. Click **System > Security > ARP Protection**.



2. Select the desired NIC and then select **Enable ARP Protection**.
3. Obtain the gateway's MAC address automatically, or select **Custom** and input the MAC address.
4. Click **Apply** to save the settings.

Video Watermark

Encrypt custom information in videos to prevent unauthorized alteration.

1. Click **System > Security**.

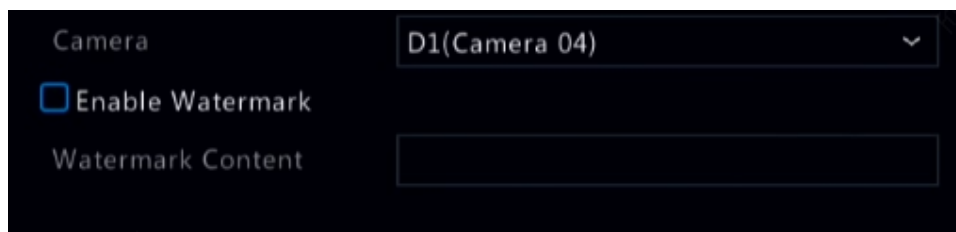

2. Select the desired camera and then select **Enable Watermark**.
3. Enter watermark content.
4. Click **Apply** to save the settings.

System Maintenance

System Information

Click **Maintain** > **System Info** to view the basic NVR information for maintenance purpose.

System Info

View the basic information such as the device model, serial number, firmware version, build date and operation time.

Basic Info	
Model	NVR
Serial No.	210235T0
Firmware Version	NVR-B31
Build Date	2019-04-22
Operation Time	0 Day(s) 15 Hour(s) 19 Minute(s)

Camera status

Click the **Camera** tab to view camera status (online or offline with possible offline cause) and status of alarm functions such as motion detection, tampering, video loss and audio detection. Off means disabled, and on means enabled.

Camera ID	Name	Status	Motion	Tampering	Video Loss	Audio
D1	Camera 04	Online	Off	Off	On	Off
D2	D1(3MP)	Online	On	Off	On	Off
D3	wan1lun20029	Online	Triggered	Off	On	Off
D4	IP Camera 04	Online	Triggered	Off	On	Off
D5	11111	Online	On	Off	On	Off

Recording status

Click the **Recording** tab to view recording status and stream settings.

Camera ID	Name	Type	Status	Diagnosis	Stream Type	fps	kbps	Resolution
D1	Camera 04	Normal	Ongoing	Normal	Main Stream	25	2590	1920X1080
D2	D1(3MP)	Normal	Ongoing	Normal	Main Stream	20	530	2592X1520
D3	wan1lun20029	Event	Ongoing	Normal	Main Stream	15	496	3000X3000
D4	IP Camera 04	Event	Ongoing	Normal	Main Stream	30	271	1920X1080
D5	11111	Normal	Ongoing	Normal	Main Stream	25	162	1920X1080

NOTE: Due to automatic rounding of numbers, the frame rate value may have 1-2 fps difference on what is shown on the OSD.

Online user

Click the **Online User** tab for information about users who are currently logged in.

<input type="checkbox"/> No.	Username	IP Address	Login Time
1	admin	127.0.0.1	2019-05-17 09:11:47

Disk status

Click the **Disk** tab to view the hard disk status and disk properties.

Disk No.	Total(GB)	Free(GB)	Status	Vendor	Property
1	1842.39	1716.50	Normal		Read/Write

Total Capacity(GB)	1842.39
Free Space(GB)	1716.50

Network Information

Traffic

Click **Maintain** > **Network Info** > **Traffic** to view network traffic information.



Network Detection

Click **Maintain** > **Network Info** > **Net Detect**.

To test network delay and packet loss rate, enter the test address and then click **Test**.

NOTE: The test packet size is 3000 bytes by default and can be changed as needed.

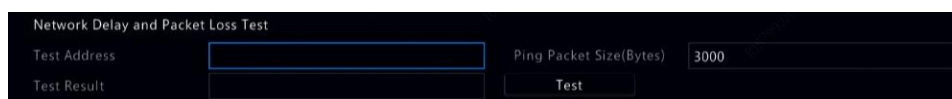

The screenshot shows the 'Network Delay and Packet Loss Test' form. It includes a 'Test Address' input field, a 'Ping Packet Size(Bytes)' input field set to 3000, and a 'Test' button.

To capture and save packets, select the USB storage device, specify the port number and IP address, and then click  right to the desired NIC. The captured packets are saved as a backup file in the root directory of the USB storage device. You may click **Open** to view the file.

NOTE:

- The packet size is 1520 bytes by default and can be changed as needed.
- The backup file of the captured packets is named in *NIC name_time.pcap* format.
- Packets cannot be captured if it is already started on the Web interface.
- If you use PPPoE, a virtual NIC will appear in the list after the dial-up succeeds, and you may capture packets sent to and from this NIC.

Network Settings

Click **Maintain** > **Network Info** > **Network** to view network settings.

Network Statistics

Click **Maintain > Network Info > Network Statistics**. Bandwidth usage statistics are displayed.

Type	Bandwidth
IP Camera	7936Kbps
Remote Live View	0bps
Remote Playback	0bps
Idle Receive Bandwidth	312Mbps
Idle Send Bandwidth	320Mbps

NOTE:



- Insufficient receiving bandwidth (**Idle Receive Bandwidth**) may cause the connected cameras to be offline.
- When the sending bandwidth (**Idle Send Bandwidth**) is insufficient, remote live view, playback or download may fail on the NVR.

Log Query

Logs contain information about user-performed operations and device status. By analyzing logs, you can keep track of device operation status and view detailed alarm information.

1. Click **Maintain > Log**.
2. Set query conditions, including the start and end times, main type and sub type.
3. Click **Query**.

Start Time	2019-05-17 00:00:00					
End Time	2019-05-17 23:59:59					
Main Type	All					
Sub Type	All Types					
Username	Operation Time	Camera	Play	Main Type	Sub Type	Details
admin	2019-05-17 10:18:26	D3		Alarm	Motion Detection Started	
	2019-05-17 10:18:10		—	Operation	Quick Search IP Camera	
	2019-05-17 10:17:54	D3		Alarm	Motion Detection Ended	
	2019-05-17 10:17:34	D3		Alarm	Motion Detection Started	
	2019-05-17 10:17:26	D3		Alarm	Motion Detection Ended	
	2019-05-17 10:17:22	D4		Alarm	Motion Detection Started	
	2019-05-17 10:17:21	D4		Alarm	Motion Detection Ended	
	2019-05-17 10:16:21	D3		Alarm	Motion Detection Started	

4. If  is displayed under **Play**, you may click  to view the recording that started one minute before the alarm time and ended ten minutes after the alarm time.  means this functions is not available.

5. To export logs to an external storage device, click **Export**, set the export destination and format, and then click **Backup**.

Import/Export

System Import / Export

Configurations and maintenance information can be exported to a storage device and saved as files for backup. A configuration file can also be imported to the NVR to restore configurations. The configuration file of an NVR can be imported to multiple NVRs of the same model if you want them to have the same settings. If the imported configuration file contains camera information, the related camera will be added to all the NVRs.

Only admin can perform these operations.

1. Click **Maintain > Backup**.
2. To export device configurations, specify the destination directory and then click **Export**. A .xml file will be created in the specified directory when export is completed.
3. To export maintenance information, specify the destination directory and then click **Export Maintain Info**. A .tgz file will be created in the specified directory when export is completed.
4. To import device configurations, double-click the target folder containing the .xml file, select the file, and then click **Import**.



CAUTION: Delete files with caution. Deleted files cannot be recovered.

System Restoration

Use this function to restore some or all factory default settings. The NVR will restart automatically to complete this operation. Recordings and operation logs will not be deleted.

1. Click **Maintain > Restore**.
2. Click **Default** to restore factory default settings except network and user settings, or click **Factory Default** to restore all factory default settings.

Automatic Maintenance

Set the NVR to restart as scheduled and delete files (including recordings and snapshots) as needed. Only admin can perform this operation.

1. Click **Maintain > Auto-Function**.
2. Set an auto-restart time, and choose a way to delete files automatically.

Auto-Restart	Never	02:00	
Auto-Delete File(s)	Never		day(s) ago

Note: Auto-Delete File(s) automatically deletes recordings and images saved on hard disk.



CAUTION: Files deleted automatically cannot be recovered.

System Upgrade

NOTE: This feature is disabled by default, contact your sales administrator for assistance.

Hard Disk Detection

S.M.A.R.T. Test

Click **Maintain > HDD > S.M.A.R.T. Test** to do S.M.A.R.T. test.

S.M.A.R.T. (enabled by default) checks the head, platter, motor, and circuit of hard disks to evaluate their health status. The overall evaluation results include **Healthy**, **Failure**, and **Bad Sectors**. It is recommended to replace the disk immediately if the status is **Failure**.

Continue to use the disk when it fails to pass evaluation.

Select Disk: Slot1

Test Type: Short

Test Status: Not tested

Vendor: TOSHIBA

Model: TOSHIBA MD04ABA400V

Firmware Version: FP1T

Disk Temperature(°C): 34

Operation Time(day): 501

Self-Evaluation: Pass

Overall Evaluation: Healthy

ID	Attribute Name	Status	Flag	Threshold	Value	Worst	Raw Value
1	Raw_Read_Error_Rate	Healthy	0x000b	50	100	100	0
2	Throughput_Performance	Healthy	0x0005	50	100	100	0
3	Spin_Up_Time	Healthy	0x0027	1	100	100	5228
4	Start_Stop_Count	Healthy	0x0032	0	100	100	25
5	Reallocated_Sector_Count	Healthy	0x0033	50	100	100	0

NOTE:

- Some hard disks only support some of the test items.
- The system provides three test types: Short, Extended, and Conveyance. Extended tests detect more thoroughly and thus take longer time than Short tests. Conveyance tests mainly detect data transmission problems.



CAUTION: Using a faulty disk is risky. Faulty disks should be replaced immediately.

Contact your local dealer for information about hard disks.

Bad Sector Detection

Bad sector detection checks for bad sectors in hard disks.

1. Click **Maintain > HDD > Bad Sector Detect**.
2. Select the desired disk and detection type, and then click **Detect** to start detection. Click **Stop** if you want to stop.



CAUTION: The detection stops automatically when the error count reaches 100.

Shutdown

Click **Shutdown** to log out, restart or shut down as needed. To shut down the NVR, click the **Home** icon from the Live view, and then click **Shutdown**. Click **Yes** to confirm.



CAUTION: Unsaved settings will be lost if the NVR is shut down unexpectedly, for example, due to a power failure. An incorrect shutdown during a system upgrade may cause startup failures.

Part II Web-Based Operations

Before You Begin

You may access and manage your NVR remotely using a web browser on a PC (through the Web interface). Check the following before you begin:

- Access will be authenticated during login, and operation permissions will be required.
- The PC is operating properly and has a network connection to the NVR.
- The PC uses the Windows XP, Windows 7 or Windows 8 operating system.
- A Web browser has been installed on the PC. Microsoft Internet Explorer 8.0 or higher is recommended. Firefox, Chrome and Opera browsers are also supported.
- A 32-bit Web browser is still required even if you are using a 64-bit operating system.

NOTE:

- The parameters that are grayed out on the Web GUI cannot be modified. The parameters and values displayed may vary with NVR model.
- The figures are for illustration purpose only and may vary with NVR model.

Login

1. Open a Web browser on your PC and browse to the login page by entering the IP address (**192.168.1.30** by default) of your NVR.

You may need to install a plug-in as prompted at your first login. Close the Web browser when the installation starts.

2. In the login dialog box, enter the correct username and password (**123456** for admin) and then click **Login**.



CAUTION: The default password is intended only for the first login and should be changed to a strong one containing at least eight characters including uppercase and lowercase letters, digits and symbols after your first login to ensure security.







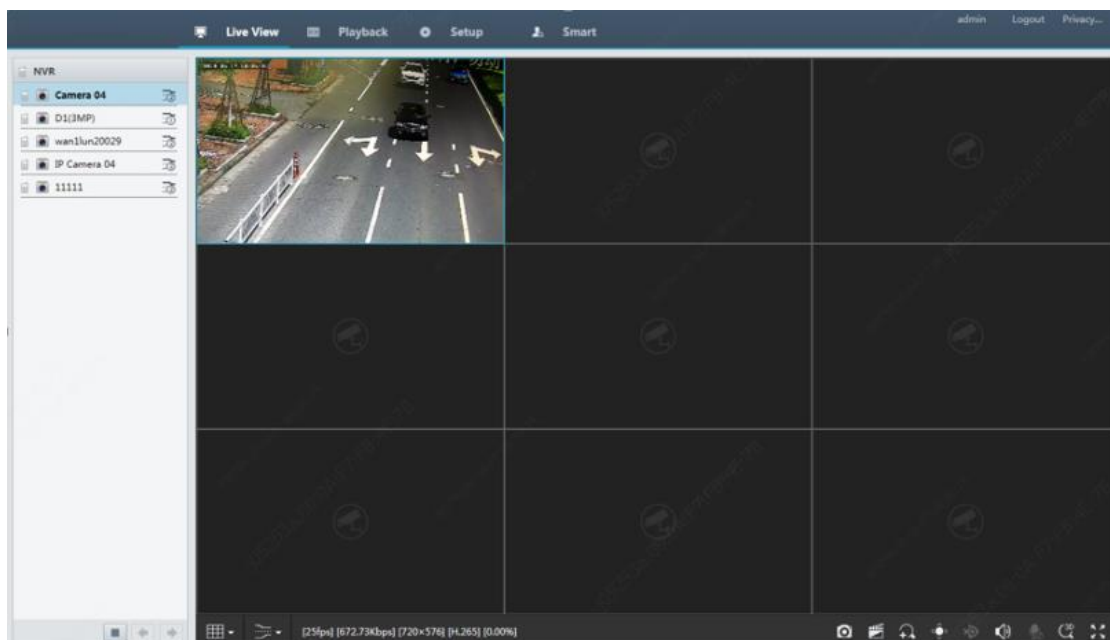



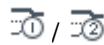

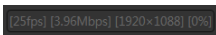

- **Strong:** Contains at least 8 characters from at least three of the four types: upper-case letter, lower-case letter, special character, digit.
- **Weak:** Contains at least 8 characters from two of the four types: upper-case letter, lower-case letter, special character, digit.

Live View



The **Live View** page is displayed when you are logged in. The following figure shows an example.



Live View Window Control Buttons

Button	Description	Button	Description
	Two-way audio		Main/Sub stream
	Start or stop live view in all windows		Previous and next screen
	Switch screen layout		Full screen
	Select stream type		Shows the current frame rate, bit rate, resolution, and packet loss rate
	Take a snapshot		Start zoom
	Local recording		Turn on or off audio; adjust sound volume.
	Adjust MIC volume		3D positioning
	Open or close the control panel	—	—

NOTE:

- The  icon means two-way audio is available. Click to start two-way audio with the NVR or a camera (depending on where the icon is displayed).
- Only the main stream  is displayed when the camera is offline or it supports only one stream.
- A snapshot file is named in this format: *IP_camera ID_snapshot time*. The snapshot time is in *YYYYMMDDHHMMSSSMS* format.







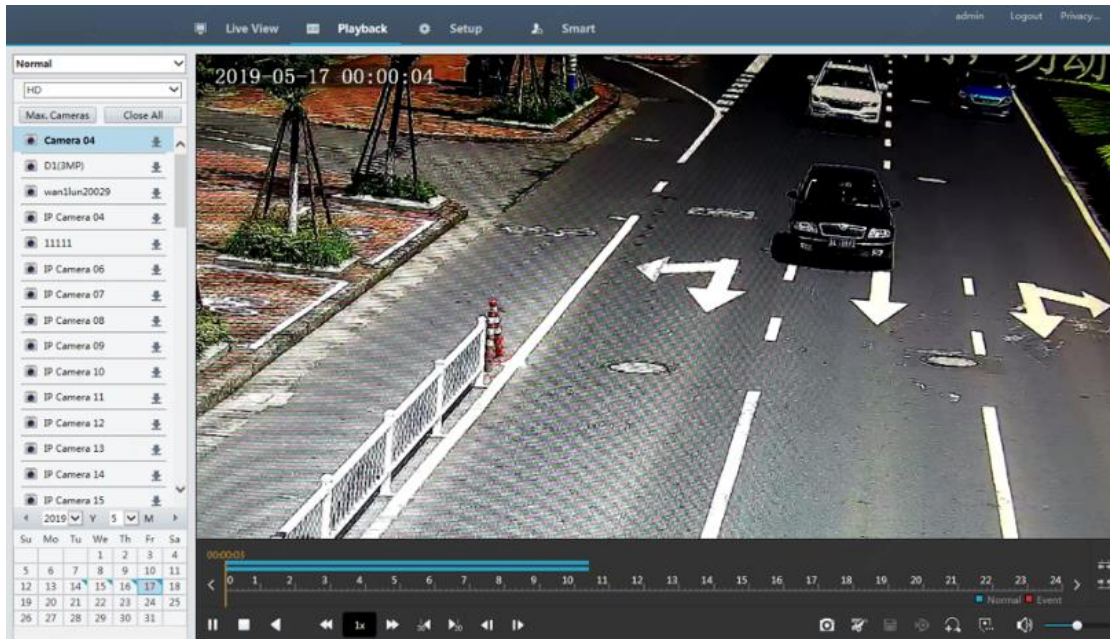





- By default, snapshots are saved in this directory:
C:\Users*username*\Surveillance\Snap*system date*. The system date is in *yyyy-mm-dd* format.
- A local recording is named in this format: *IP_camera ID_S recording start time E recording end time*. The recording start and end times are in *hh-mm-ss* format.
- By default, local recordings are saved in this directory:
C:\Users*username*\Surveillance\Record*system date*. The system date is in *yyyy-mm-dd* format.

Playback

Click **Playback** on the top to show the **Playback** page. The following figure shows an example.



Playback Control Buttons

Button	Description	Button	Description
	Play/Pause		Stop
	Reverse		Slow down or speed up
	Rewind or forward 30 seconds		Rewind or forward by frame
	Previous or next period		Clip video/pause
	Save video clip		Take a snapshot
	Zoom		Adjust sound volume; turn on or off sound

Configuration

Click **Setup** on the top, and then click the menus on the left to configure parameters.

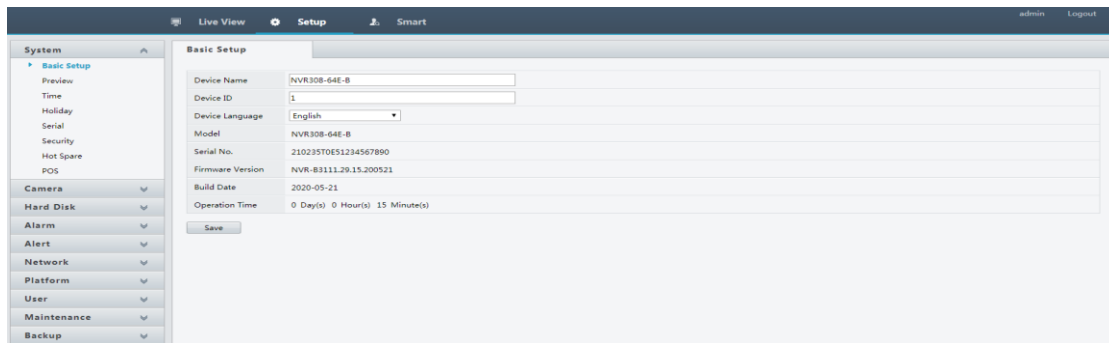

Appendix A Typical Applications

Typical Application 1

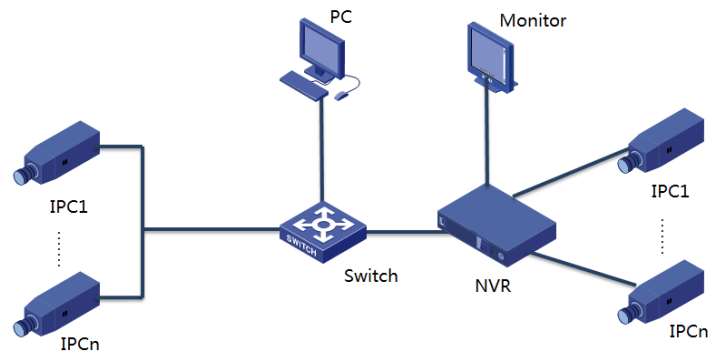

The NVR, IP cameras, and PC are connected on a private network (or LAN). The IP cameras can be connected to the NVR directly or via a switch. And you manage the NVR and the connected IP cameras through the monitor or using a web browser on the PC.

Typical Application 2

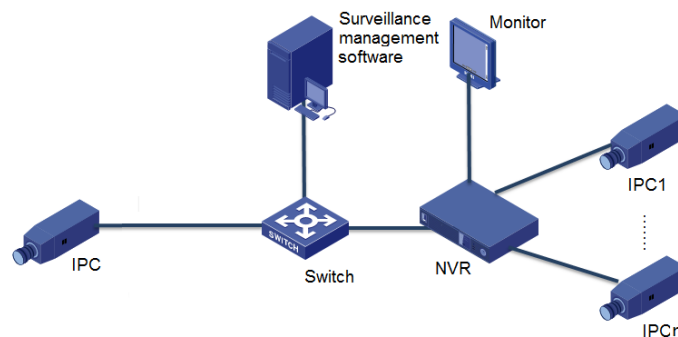

The NVR, IP cameras, and PC are connected on a private network (or LAN). The IP cameras can be connected to the NVR directly or via a switch. The PC is installed with surveillance management software. You can manage the NVR and the connected IP cameras using the surveillance software or through the monitor.

Appendix B Acronyms

Acronym	Description
CBR	Constant Bit Rate
DDNS	Dynamic Domain Name Service
DHCP	Dynamic Host Configuration Protocol
DST	Daylight Saving Time
DVS	Digital Video Server
FTP	File Transfer Protocol
HDMI	High Definition Multimedia Interface
HTTPS	Hypertext Transfer Protocol Over Secure Sockets Layer
IPC	IP Camera
JPEG	Joint Photographic Experts Group
MTU	Maximum Transfer Unit
NAT	Network Address Translation
NIC	Network Interface Card
NTP	Network Time Protocol
NVR	Network Video Recorder
ONVIF	Open Network Video Interface Forum
PoE	Power over Ethernet
PPPoE	Point-to-Point Protocol over Ethernet
PTZ	Pan, Tilt, Zoom
P2P	Peer-to-Peer
RAID	Redundant Arrays of Independent Disks
RTSP	Real-Time Streaming Protocol
SDK	Software Development Kit
S.M.A.R.T.	Self-Monitoring, Analysis and Reporting Technology
UPnP	Universal Plug-and-Play
USB	Universal Serial Bus
VGA	Video Graphics Array
VBR	Variable Bit Rate

Appendix C FAQs

Problem	Possible Cause and Solution
Forgot the login password	Double-click the lower left corner of the login dialog box as admin. A dialog box appears. <ul style="list-style-type: none"> Note down the serial number and then contact your dealer for a temporary password. Log in with the temporary password and then reset your password. Use your mobile surveillance app to scan the QR code (Settings > Forgot Device Password).
Cannot open the login page with the default IP address (192.168.1.30)	Please try 192.168.0.30.
The Web plugin (ActiveX) cannot be loaded.	<ul style="list-style-type: none"> Close your web browser when the installation starts. Disable the firewall and close the anti-virus program on your computer. Enable your Internet Explorer(IE) to check for newer versions of the stored pages every time you visit the webpage (Tools > Internet Options > General > Settings). Add your NVR's IP address to the trusted sites in your IE (Tools > Internet Options > Security). Add your NVR's IP address to the Compatibility View list in your IE (Tools > Compatibility View Settings). Clear your IE's cache.
No images are displayed in live view on the Web interface.	Check if the bit rate is 0Mbps in the live view window. <ul style="list-style-type: none"> If yes, check if the firewall has been disabled, and the anti-virus program has been stopped on your computer. If not, maybe it is because the graphics card driver on your computer is not working properly. Try installing the driver again.
A camera is offline, and No Link is displayed.	Click Maintain > System Info > Camera . The cause is displayed under Status . Common causes include disconnected network, incorrect username or password, weak password, insufficient bandwidth. <ul style="list-style-type: none"> Check network connection and network configurations.

Problem	Possible Cause and Solution
	<ul style="list-style-type: none"> • If it indicates incorrect username or password, check that the camera password set in the NVR is the one used to access the camera's Web interface. • If it indicates denied access for weak password, log in to the camera's Web interface and set a strong password. • If it indicates insufficient bandwidth, delete other online IP devices in the NVR.
<p>The NVR displays live video for some cameras and No Resource for others.</p>	<ul style="list-style-type: none"> • Set the camera to encode the sub stream, and decrease its resolution to D1. • Set the NVR to use the sub stream first for live view.
<p>A camera goes online and offline repeatedly.</p>	<ul style="list-style-type: none"> • Check if network connection is stable. • Upgrade the firmware for the camera and the NVR. Contact your dealer for the latest versions.
<p>Live view is normal, but the recording cannot be found.</p>	<ul style="list-style-type: none"> • Check that a recording schedule has been properly configured. • Check if the time and time zone configured in the NVR are correct. • Check if the hard disk storing the recording has been damaged. • Check if the desired recording has been overwritten.
<p>Motion detection is not effective.</p>	<ul style="list-style-type: none"> • Check that motion detection is enabled, and the motion detection area is properly configured. • Check that detection sensitivity is properly set. • Check that the arming schedule is properly configured.
<p>A hard disk cannot be identified by the NVR.</p>	<ul style="list-style-type: none"> • Use the power adapter delivered with your NVR. • Power down the NVR and then mount the hard disk again. • Try another disk slot. • The disk is not compatible with your NVR. Contact your dealer for a list of compatible disk models.
<p>The mouse does not work.</p>	<ul style="list-style-type: none"> • Use the mouse delivered with your NVR. • Make sure no cable is extended.



Copyright © 2021, ACTi Corporation All Rights Reserved
7F, No. 1, Alley 20, Lane 407, Sec. 2, Ti-Ding Blvd., Neihu District, Taipei, Taiwan 114, R.O.C.
TEL : +886-2-2656-2588 FAX : +886-2-2656-2599
Email: sales@acti.com